



zeus Marking Technology

- marking workpieces in seconds
- on a wide variety of geometries independent of the workpiece diameter
- changing marking text thanks to interchangeable marking segments
- for machines with small installation space
- marking up to a shoulder

APPLICATIONS

Where and how can workpieces be marked?

The example shows that you can mark at practically any position. Whether you require marking on spherical or conical surface, up to a shoulder, on end face or inner surface – zeus marking tools will satisfy your requirements.

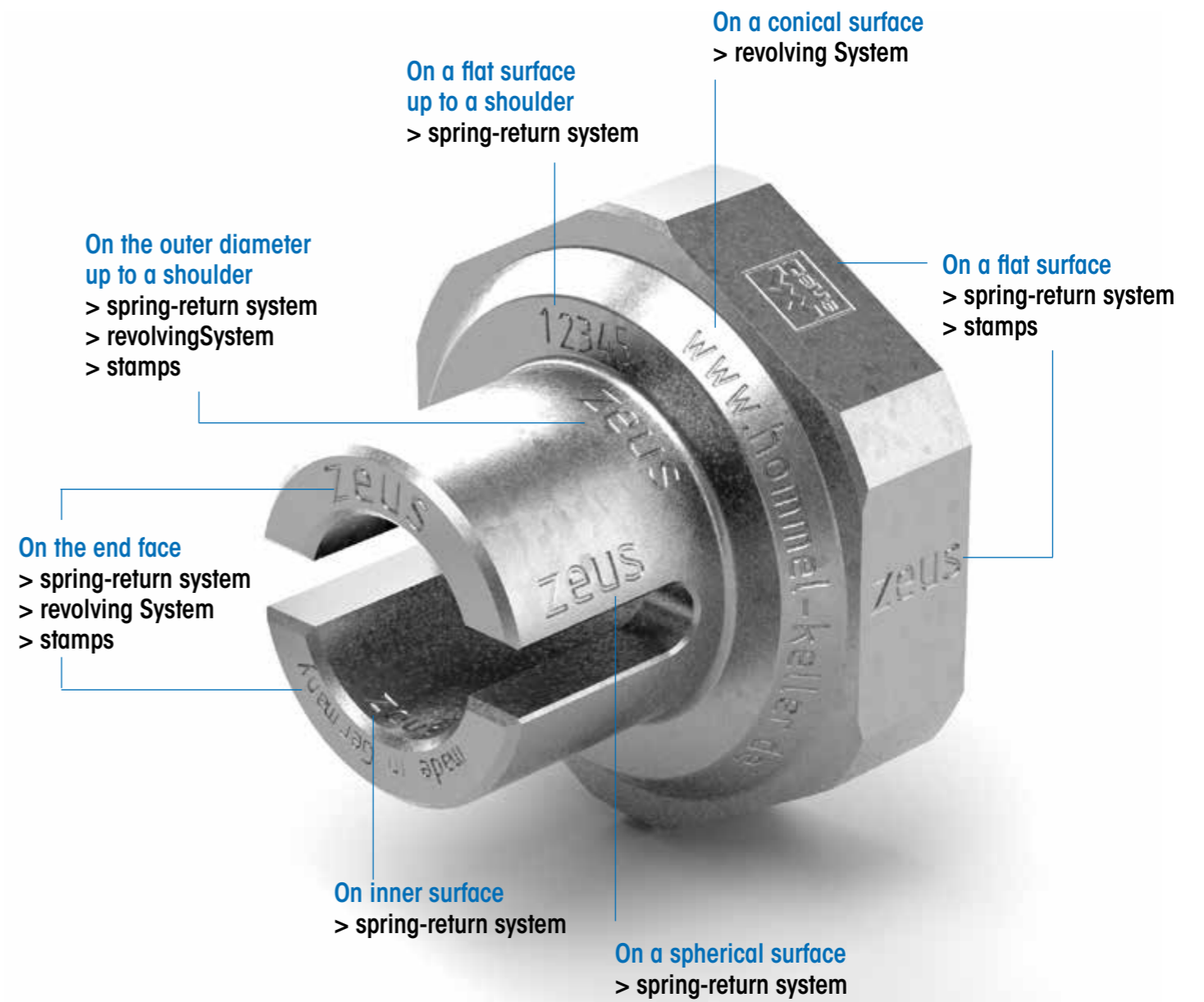

In marking technology
there are two different processes:
spring-return and the
revolving system.

Both processes have their special applications
and areas of utilisation.

Application Examples marking tools:

432:
Very flexible tool for
different workpiece geometries
and changing marking text

**MARKING SEGMENTS
IMMEDIATELY AVAILABLE:
A-Z, 0-9, -/.**



422:
Extremely compact design
ideal for Swiss type lathes









131 / 311:
Extremely cost efficient
for consistent geometry
and marking text









OVERWIEV

MARKING TOOLS

Spring-return system

Marking tool	Marking segment / Marking roll	Shank [mm] (adaptable to shank size)	Marking on workpiece, on different geometries	Marking up to a shoulder	Changing marking text possible	Center height integrated
 432 (P. 48)	 Marking segment No. 43	8 (10 / 12 / 16) 16 (20 / 25)	> on a flat surface > on a spherical surface > on the end face > on the outer diameter	✓	✓	✓
 431 (P. 50)	 Marking segment No. 42	16 (20 / 25)	> on a flat surface > on a spherical surface > on the end face > on the outer diameter	✗	✓	✓
 422 (P. 52)	 Marking roll No. 41	8 (10 / 12 / 16)	> on a flat surface > on a spherical surface > on the end face > on the outer diameter	✓	✗	✓
 421 (P. 53)	 Marking roll No. 41	16 (20 / 25)	> on a flat surface > on a spherical surface > on the end face > on the outer diameter	✗	✗	✓

Revolving system

 131 (P. 54)	 Marking roll No. 41	10 / 12 / 16 20 / 25	> on a conical surface > on the end face > on the outer diameter	✗	✗	✓
 311 (P. 55)	 Marking roll No. 40-K	application- specific	> on a conical surface > on the end face	✗	✗	✓
 312 (P. 55)	 Marking roll No. 40-K	application- specific	> on a conical surface > on the end face	✗	✗	✓



MARKING TOOL SET 432

Spring-return system



PRODUCT FEATURES

- modular shank design
- top edge of shank = centre height
- set screws in shank for correcting alignment
- hardened pin
- exact positioning of the marking on the circumference of the workpiece
- marking up to a shoulder
- center height corresponds to the first marking point
- marking position individually adjustable
- sets in high quality packaging

Available from stock

Item no. (right-hand version)	Item no. (left-hand version)	Model / Sets (with shank adapter)	Item no. E-Kit		
			right	left	
31002833 <input checked="" type="checkbox"/> (Set small version for segments Ø 30)	31002915 <input checked="" type="checkbox"/> (Set small version for segments Ø 30)	432-08	21BHR1081	21BHR1082	
		with adapter 10 x 10 mm			
		with adapter 12 x 12 mm			
		with adapter 16 x 16 mm			
		inkl. start- u. end segment			
31002849 <input checked="" type="checkbox"/> (Set big version for segments Ø 50)	31002873 <input checked="" type="checkbox"/> (Set big version for segments Ø 50)	432-16	21BHR1111	21BHR1112	
		with adapter 20 x 20 mm			
		with adapter 25 x 25 mm			
		inkl. start- u. end segment			

Item no. (right-hand version)	Item no. (left-hand version)	Dimensions [mm]						
		a	b	c	d	e	f	x
31002833 <input checked="" type="checkbox"/> (small version)	31002915 <input checked="" type="checkbox"/> (small version)	8	8	112.5	31.5	32.5	30	1
		10	10	112.5	31.5	32.5	30	1
		12	12	112.5	31.5	32.5	30	1
		16	16	112.5	31.5	32.5	31	1
31002849 <input checked="" type="checkbox"/> (big version)	31002873 <input checked="" type="checkbox"/> (big version)	16	16	137.5	31.5	57.5	48	1
		20	20	137.5	31.5	57.5	48	1
		25	25	137.5	31.5	57.5	48	1

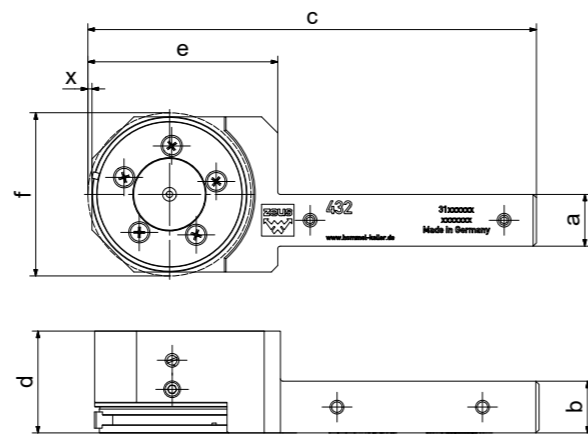

CHANGING MARKING TEXT



MARKING SEGMENTE Nr. 43

(for tool set 432)



SEGMENTS Ø 30 - small version
for Item no. 31002833 / 31002915

Standard design	
flank angle	90°
dimension (Ø x width x bore, mm)	30 x 8 x 18
font	according to DIN 1451



SEGMENTS Ø 50 - big version
for Item no. 31002849 / 31002873

Standard design	
flank angle	90°
dimension (Ø x width x bore, mm)	50 x 8 x 38
font	according to DIN 1451

Available from stock

Item no. character height 2 mm	Item no. character height 3 mm	Segments designations
85000000 <input checked="" type="checkbox"/>		Start segment
85001018 <input checked="" type="checkbox"/>		Letter set A-Z
85000992 <input checked="" type="checkbox"/>	85000346 <input checked="" type="checkbox"/>	A
85000993 <input checked="" type="checkbox"/>	85000356 <input checked="" type="checkbox"/>	B
85000994 <input checked="" type="checkbox"/>	85000344 <input checked="" type="checkbox"/>	C
85000995 <input checked="" type="checkbox"/>	85000347 <input checked="" type="checkbox"/>	D
85000996 <input checked="" type="checkbox"/>	85000348 <input checked="" type="checkbox"/>	E
85000997 <input checked="" type="checkbox"/>	85000349 <input checked="" type="checkbox"/>	F
85000998 <input checked="" type="checkbox"/>	85000350 <input checked="" type="checkbox"/>	G
85000999 <input checked="" type="checkbox"/>	85000351 <input checked="" type="checkbox"/>	H
85001000 <input checked="" type="checkbox"/>	85001407 <input checked="" type="checkbox"/>	I
85001001 <input checked="" type="checkbox"/>	85000352 <input checked="" type="checkbox"/>	J
85001002 <input checked="" type="checkbox"/>	85000353 <input checked="" type="checkbox"/>	K
85001003 <input checked="" type="checkbox"/>	85000354 <input checked="" type="checkbox"/>	L
85001004 <input checked="" type="checkbox"/>	85000355 <input checked="" type="checkbox"/>	M
85001005 <input checked="" type="checkbox"/>	85000852 <input checked="" type="checkbox"/>	N
85001006 <input checked="" type="checkbox"/>	85001408 <input checked="" type="checkbox"/>	O
85001007 <input checked="" type="checkbox"/>	85000855 <input checked="" type="checkbox"/>	P
85001008 <input checked="" type="checkbox"/>	85001409 <input checked="" type="checkbox"/>	Q
85001009 <input checked="" type="checkbox"/>	85001063 <input checked="" type="checkbox"/>	R
85001010 <input checked="" type="checkbox"/>	85000856 <input checked="" type="checkbox"/>	S
85001011 <input checked="" type="checkbox"/>	85001410 <input checked="" type="checkbox"/>	T
85001012 <input checked="" type="checkbox"/>	85001411 <input checked="" type="checkbox"/>	U
85001013 <input checked="" type="checkbox"/>	85001412 <input checked="" type="checkbox"/>	V
85001014 <input checked="" type="checkbox"/>	85000851 <input checked="" type="checkbox"/>	W
85001015 <input checked="" type="checkbox"/>	85001413 <input checked="" type="checkbox"/>	X
85001016 <input checked="" type="checkbox"/>	85001414 <input checked="" type="checkbox"/>	Y
85001017 <input checked="" type="checkbox"/>	85001415 <input checked="" type="checkbox"/>	Z
85000991 <input checked="" type="checkbox"/>		Numeral set 0-9
85000981 <input checked="" type="checkbox"/>	85000622 <input checked="" type="checkbox"/>	0
85000982 <input checked="" type="checkbox"/>	85000623 <input checked="" type="checkbox"/>	1
85000983 <input checked="" type="checkbox"/>	85000345 <input checked="" type="checkbox"/>	2
85000984 <input checked="" type="checkbox"/>	85000357 <input checked="" type="checkbox"/>	3
85000985 <input checked="" type="checkbox"/>	85000624 <input checked="" type="checkbox"/>	4
85000986 <input checked="" type="checkbox"/>	85000625 <input checked="" type="checkbox"/>	5
85000987 <input checked="" type="checkbox"/>	85000626 <input checked="" type="checkbox"/>	6
85000988 <input checked="" type="checkbox"/>	85000627 <input checked="" type="checkbox"/>	7
85000989 <input checked="" type="checkbox"/>	85000628 <input checked="" type="checkbox"/>	8
85000990 <input checked="" type="checkbox"/>	85000629 <input checked="" type="checkbox"/>	9
85002186 <input checked="" type="checkbox"/>		space segment
85001654 <input checked="" type="checkbox"/>	85001257 <input checked="" type="checkbox"/>	special character - (Minus)
85001019 <input checked="" type="checkbox"/>	85002485 <input checked="" type="checkbox"/>	special character . (Point)
85001059 <input checked="" type="checkbox"/>	85001537 <input checked="" type="checkbox"/>	special character / (Slash)
85000003 <input checked="" type="checkbox"/>		End segment

Item no. character height 2 mm	Item no. character height 3 mm	Segments designation
85000113 <input checked="" type="checkbox"/>		Start segment
85001819 <input checked="" type="checkbox"/>		Letter set A-Z
85001793 <input checked="" type="checkbox"/>	85001108 <input checked="" type="checkbox"/>	A
85001794 <input checked="" type="checkbox"/>	85001109 <input checked="" type="checkbox"/>	B
85001795 <input checked="" type="checkbox"/>	85001289 <input checked="" type="checkbox"/>	C
85001796 <input checked="" type="checkbox"/>	85001533 <input checked="" type="checkbox"/>	D
85001797 <input checked="" type="checkbox"/>	85001565 <input checked="" type="checkbox"/>	E
85001798 <input checked="" type="checkbox"/>	85001130 <input checked="" type="checkbox"/>	F
85001799 <input checked="" type="checkbox"/>	85001581 <input checked="" type="checkbox"/>	G
85001800 <input checked="" type="checkbox"/>	85001534 <input checked="" type="checkbox"/>	H
85001801 <input checked="" type="checkbox"/>	85001566 <input checked="" type="checkbox"/>	I
85001802 <input checked="" type="checkbox"/>	85001567 <input checked="" type="checkbox"/>	J
85001803 <input checked="" type="checkbox"/>	85001535 <input checked="" type="checkbox"/>	K
85001804 <input checked="" type="checkbox"/>	85001568 <input checked="" type="checkbox"/>	L
85001805 <input checked="" type="checkbox"/>	85001569 <input checked="" type="checkbox"/>	M
85001806 <input checked="" type="checkbox"/>	85001570 <input checked="" type="checkbox"/>	N
85001807 <input checked="" type="checkbox"/>	85001571 <input checked="" type="checkbox"/>	O
85001808 <input checked="" type="checkbox"/>	85001572 <input checked="" type="checkbox"/>	P
85001809 <input checked="" type="checkbox"/>	85001573 <input checked="" type="checkbox"/>	Q
85001810 <input checked="" type="checkbox"/>	85001574 <input checked="" type="checkbox"/>	R
85001811 <input checked="" type="checkbox"/>	85001575 <input checked="" type="checkbox"/>	S
85001812 <input checked="" type="checkbox"/>	85001576 <input checked="" type="checkbox"/>	T
85001813 <input checked="" type="checkbox"/>	85001290 <input checked="" type="checkbox"/>	U
85001814 <input checked="" type="checkbox"/>	85001577 <input checked="" type="checkbox"/>	V
85001815 <input checked="" type="checkbox"/>	85001578 <input checked="" type="checkbox"/>	W
85001816 <input checked="" type="checkbox"/>	85001579 <input checked="" type="checkbox"/>	X
85001817 <input checked="" type="checkbox"/>	85001580 <input checked="" type="checkbox"/>	Y
85001818 <input checked="" type="checkbox"/>	85001536 <input checked="" type="checkbox"/>	Z
85001431 <input checked="" type="checkbox"/>		Numeral set 0-9
85001421 <input checked="" type="checkbox"/>	85000466 <input checked="" type="checkbox"/>	0
85001422 <input checked="" type="checkbox"/>	85000467 <input checked="" type="checkbox"/>	1
85001423 <input checked="" type="checkbox"/>	85000468 <input checked="" type="checkbox"/>	2
85001424 <input checked="" type="checkbox"/>	85000469 <input checked="" type="checkbox"/>	3
85001425 <input checked="" type="checkbox"/>	85000470 <input checked="" type="checkbox"/>	4
85001426 <input checked="" type="checkbox"/>	85000471 <input checked="" type="checkbox"/>	5
85001427 <input checked="" type="checkbox"/>	85000472 <input checked="" type="checkbox"/>	6
85001428 <input checked="" type="checkbox"/>	85000473 <input checked="" type="checkbox"/>	7
85001429 <input checked="" type="checkbox"/>	85000474 <input checked="" type="checkbox"/>	8
85001430 <input checked="" type="checkbox"/>	85000475 <input checked="" type="checkbox"/>	9
85003870 <input checked="" type="checkbox"/>		space segment
85001912 <input checked="" type="checkbox"/>	85001600 <input checked="" type="checkbox"/>	special character - (Minus)
85002486 <input checked="" type="checkbox"/>	85002487 <input checked="" type="checkbox"/>	special character . (Point)
85001857 <input checked="" type="checkbox"/>	85001131 <input checked="" type="checkbox"/>	special character / (Slash)
85000114 <input checked="" type="checkbox"/>		End segment



MARKING TOOL SET 431

Spring-return system



PRODUCT FEATURES

- modular shank design
- top edge of shank = centre height
- set screws in shank for correcting alignment
- hardened pin
- exact positioning of the marking on the circumference of the workpiece
- center height corresponds to the first marking point
- marking position individually adjustable
- sets in high quality packaging

Available from stock

Item no.	Model / Sets (with shank adapter)	Item no. E-Kit		
		right	left	
31002845 <input checked="" type="checkbox"/>	431-16	21BHR1509	21BHR1510	
	with adapter 20 x 20 mm			
	with adapter 25 x 25 mm incl. start- and endsegment			

Item no.	Dimensions [mm]						
	a	b	c	d	e	f	x
31002845 <input checked="" type="checkbox"/>	16	16	130.5	30	50.5	45	2
	20	20	130.5	30	50.5	45	2
	25	25	130.5	30	50.5	47.5	2

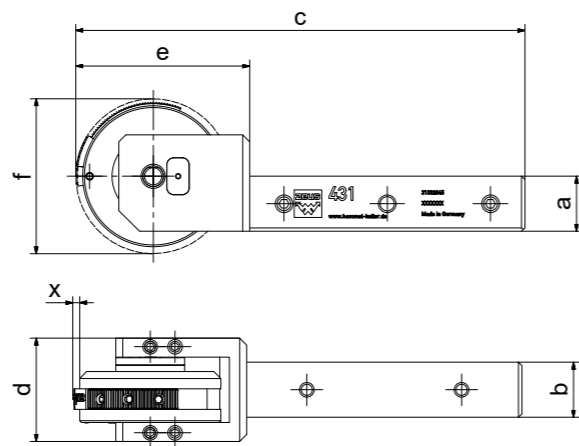

CHANGING MARKING TEXT



MARKING SEGMENTS Nr. 42 (for tool set 431)

SEGMENTS for Item no. 31002845



Standard design	
flank angle	90°
dimension (ø x width x bore, mm)	45 x 6 x 33
font	according to DIN 1451

Available from stock

Item no. character height 2 mm	Item no. character height 3 mm	Segments designations
82000067 <input checked="" type="checkbox"/>		Start segment
82002237 <input checked="" type="checkbox"/>		Letter set A-Z
82000438 <input checked="" type="checkbox"/>	82000028 <input checked="" type="checkbox"/>	A
82000439 <input checked="" type="checkbox"/>	82002232 <input checked="" type="checkbox"/>	B
82002236 <input checked="" type="checkbox"/>	82002301 <input checked="" type="checkbox"/>	C
82001063 <input checked="" type="checkbox"/>	82002302 <input checked="" type="checkbox"/>	D
82002240 <input checked="" type="checkbox"/>	82002303 <input checked="" type="checkbox"/>	E
82001064 <input checked="" type="checkbox"/>	82002304 <input checked="" type="checkbox"/>	F
82002242 <input checked="" type="checkbox"/>	82000430 <input checked="" type="checkbox"/>	G
82002243 <input checked="" type="checkbox"/>	82000431 <input checked="" type="checkbox"/>	H
82002244 <input checked="" type="checkbox"/>	82002045 <input checked="" type="checkbox"/>	I
82002245 <input checked="" type="checkbox"/>	82002308 <input checked="" type="checkbox"/>	J
82002246 <input checked="" type="checkbox"/>	82002309 <input checked="" type="checkbox"/>	K
82002247 <input checked="" type="checkbox"/>	82002310 <input checked="" type="checkbox"/>	L
82002248 <input checked="" type="checkbox"/>	82002311 <input checked="" type="checkbox"/>	M
82002249 <input checked="" type="checkbox"/>	82002312 <input checked="" type="checkbox"/>	N
82002250 <input checked="" type="checkbox"/>	82002313 <input checked="" type="checkbox"/>	O
82002251 <input checked="" type="checkbox"/>	82000429 <input checked="" type="checkbox"/>	P
82002252 <input checked="" type="checkbox"/>	82002315 <input checked="" type="checkbox"/>	Q
82001089 <input checked="" type="checkbox"/>	82002316 <input checked="" type="checkbox"/>	R
82002254 <input checked="" type="checkbox"/>	82000379 <input checked="" type="checkbox"/>	S
82002255 <input checked="" type="checkbox"/>	82002318 <input checked="" type="checkbox"/>	T
82002256 <input checked="" type="checkbox"/>	82002319 <input checked="" type="checkbox"/>	U
82002257 <input checked="" type="checkbox"/>	82002320 <input checked="" type="checkbox"/>	V
82000867 <input checked="" type="checkbox"/>	82002321 <input checked="" type="checkbox"/>	W
82002259 <input checked="" type="checkbox"/>	82002322 <input checked="" type="checkbox"/>	X
82002260 <input checked="" type="checkbox"/>	82002323 <input checked="" type="checkbox"/>	Y
82002261 <input checked="" type="checkbox"/>	82002324 <input checked="" type="checkbox"/>	Z

Item no. character height 2 mm	Item no. character height 3 mm	Segments designations
82000441 <input checked="" type="checkbox"/>	82000378 <input checked="" type="checkbox"/>	Numeral set 0-9
82000001 <input checked="" type="checkbox"/>	82000187 <input checked="" type="checkbox"/>	0
82000141 <input checked="" type="checkbox"/>	82000189 <input checked="" type="checkbox"/>	1
82000142 <input checked="" type="checkbox"/>	82000039 <input checked="" type="checkbox"/>	2
82000143 <input checked="" type="checkbox"/>	82000029 <input checked="" type="checkbox"/>	3
82000239 <input checked="" type="checkbox"/>	82000190 <input checked="" type="checkbox"/>	4
82000145 <input checked="" type="checkbox"/>	82000030 <input checked="" type="checkbox"/>	5
82000146 <input checked="" type="checkbox"/>	82000191 <input checked="" type="checkbox"/>	6
82000147 <input checked="" type="checkbox"/>	82000421 <input checked="" type="checkbox"/>	7
82000148 <input checked="" type="checkbox"/>	82000193 <input checked="" type="checkbox"/>	8
82000149 <input checked="" type="checkbox"/>	82000031 <input checked="" type="checkbox"/>	9
82000416 <input checked="" type="checkbox"/>	82000040 <input checked="" type="checkbox"/>	special character - (Minus)
82000433 <input checked="" type="checkbox"/>	82000041 <input checked="" type="checkbox"/>	special character . (Point)
82000879 <input checked="" type="checkbox"/>	82002230 <input checked="" type="checkbox"/>	special character / (Slash)
82000065 <input checked="" type="checkbox"/>		End segment



MARKING TOOL SET 422

Spring-return system



PRODUCT FEATURES

- modular shank design
- compact design - optimized for Swiss type lathe applications
- top edge of shank = centre height
- set screws in shank for correcting alignment
- hardened pin
- exact positioning of the marking on the circumference of the workpiece
- marking up to a shoulder
- center height corresponds to the first marking point
- marking position individually adjustable
- sets in high quality packaging

☑ Available from stock

Item no. (right-hand version)	Item no. (left-hand version)	Model / Sets (with shank adapter)	Size Marking roll (Ø x w x b)	Item no. E-Kit		Image
				right	left	
31002843 ☑ Tool for marking up to a shoulder	31002913 ☑ Tool for marking up to a shoulder	422	15 x 5 x 6	21BHR1505	21BHR1506	
		with adapter 10 x 10 mm				
		with adapter 12 x 12 mm				
		with adapter 16 x 16 mm				
31002846 ☑ Tool for marking up to a shoulder	31002914 ☑ Tool for marking up to a shoulder	422	15 x 7 x 6	21BHR1507	21BHR1508	
		with adapter 10 x 10 mm				
		with adapter 12 x 12 mm				
		with adapter 16 x 16 mm				

Item no. (right-hand version)	Item no. (left-hand version)	Dimensions [mm]							Image
		a	b	c	d	e	f	x	
31002843 ☑	31002913 ☑	8	8	101	24	21	16	1	
		10	10	101	24	21	18	1	
		12	12	101	24	21	20	1	
		16	16	101	24	21	24	1	

Item no. (right-hand version)	Item no. (left-hand version)	Dimensions [mm]							Image
		a	b	c	d	e	f	x	
31002846 ☑ Tool for marking up to a shoulder	31002914 ☑ Tool for marking up to a shoulder	8	8	101	24.5	21	16	1	
		10	10	101	24.5	21	18	1	
		12	12	101	24.5	21	20	1	
		16	16	101	24.5	21	24	1	

MARKING ROLL Nr. 41

(for tool set 422)



Standard design	
flank angle	90°
dimension (Ø x width x bore, mm)	15 x 5 x 6 15 x 7 x 6
font	according to DIN 1451



MARKING TOOL SET 421

Spring-return system



PRODUCT FEATURES

- modular shank design
- top edge of shank = centre height
- set screws in shank for correcting alignment
- hardened pin
- exact positioning of the marking on the circumference of the workpiece
- Marking independent of workpiece diameter
- center height corresponds to the first marking point
- marking position individually adjustable
- sets in high quality packaging

☑ Available from stock

Item no.	Model / Sets (with shank adapter)	Size Marking roll (Ø x w x b)	Item no. E-Kit		Image
			rechts	links	
31002844 ☑	421	25 x 6 x 6	21BHR1503	21BHR1504	
	with adapter 20 x 20 mm				
	with adapter 25 x 25 mm				

Item no.	Dimensions [mm]							Image
	a	b	c	d	e	f	x	
31002844 ☑	16	16	112.5	25	32.5	28.5	2.5	
	20	20	112.5	25	32.5	28.5	2.5	
	25	25	112.5	25	32.5	28.5	2.5	

MARKING ROLL Nr. 41

(for tool set 421)



Standard design	
flank angle	90°
dimension (Ø x width x bore, mm)	25 x 6 x 6
font	according to DIN 1451

APPLICATION EXAMPLE MARKING

MARK YOUR WORKPIECE IN SECONDS.



➔ INTEGRATED INTO THE MACHINING PROCESS



MARKING TOOL

Revolving system

TOOL No. 131

(catalogue page 8)

Perfect for recurring marking, impresses with its easy handling



TOOL No. 311 / 312

(catalogue page 30)

Perfect for marking on conical or flat surfaces



PRODUCT FEATURES

- easy handling
- very cost efficient and fast
- ideal for series production
- marking roll interchangeable
- marking roll is adjusted to the workpiece diameter
- top edge of shank = centre height (131 / 311 / 312)
- set screws in shank for correcting alignment

MARKING ROLL No. 40

(for tool no. 131)



MARKING ROLL No. 40-K

(for tool no. 311 / 312)



Standard design for
131 / 311 / 312

flank angle	90°
roll width [mm]	application-specific
font	according to DIN 1451

Application example

Tool No. 131 with marking roll Nr. 40

**EXTREMELY
COST EFFICIENT**

- For recurring marking on rotationally symmetrical components with constant diameter.

Application example

Tool No. 311 with marking roll Nr. 40-K

**PERFECT FOR
MARKING THE END FACE**

- When marking the end face, the calculated position of the pitch circle diameter must be observed.

