



zeus **Burnishing Tool**



1. DIAMETAL

2. BIMU

3. IFANGER

4. ARNO

5. SPHINX

6. ZEUS

7. PRAMET

8. BECKER

9. WHIZCUT

Application

The zeus burnishing tool is an all-rounder for all classic applications when burnishing surfaces – whether on cylindrical, conical, convex or concave surfaces. It is also possible to work on plane surfaces.



Burnishing Tool SET 510



Features

- n Fixed tool head
- n Can be adjusted up to $\pm 10^\circ$ thanks to integrated setting options in the shaft
- n To burnish ripples with cylindrical surfaces – limited cones and radii

Recommendations

- n Burnishing speed up to 200 m/min
- n Feed rate up to 0.2 mm/U
- n Workpiece measurement of 0.01 mm (~Rz 10) and 0.02 mm (~Rz 20)
- n It is recommended to use a cooling lubricant

TOOL VERSIONS

Order No.	Tool holder designation	Basic shaft [mm]	Dimensions [mm]							Including shaft adapter [mm]
			a	b	c	d	e	f	x	
31002859	510-10U	10 x 10	10	10	110	16	30	18	9	12 x 12
										16 x 16
31002860	510-16U	16 x 16	16	16	119.5	20	39	25	13.5	20 x 20
										25 x 25

Sets delivered without diamond tip

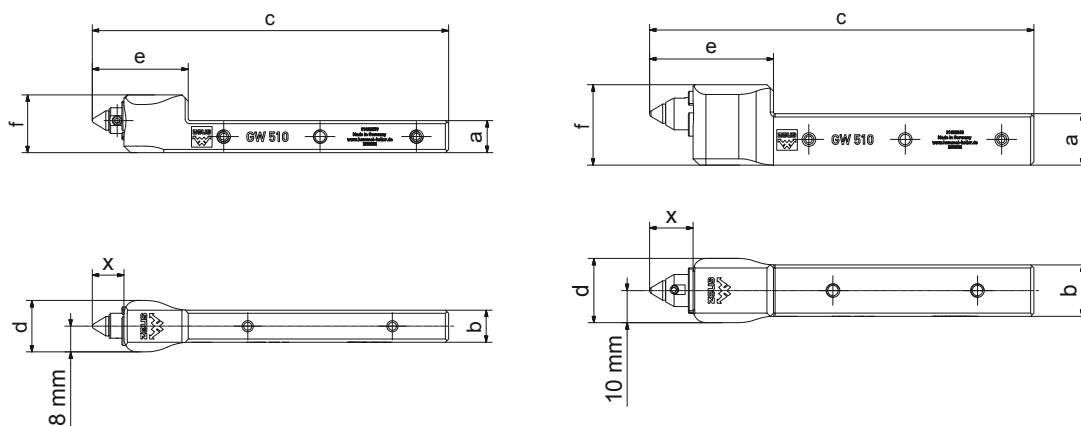

DIAMOND TIP VERSIONS

Order No.	Tip radii [mm]
06TGW0008	0.4
06TGW0009	0.6
06TGW0010	0.8
06TGW0011	1.0



Burnishing Tool SET 520



Features

- n Tool head is variably adjustable
- n Tool with universal application
- n Swivel range $\pm 90^\circ$
- n Thanks to the adjustability of the tool head, it is possible to burnish plane surfaces, conical, convex and concave geometries
- n Application up to a shoulder

Recommendations

- n Burnishing speed up to 200 m/min
- n Feed rate up to 0.2 mm/U
- n Workpiece measurement from 0.01 mm ($\sim R_z 10$) and 0.02 mm ($\sim R_z 20$)
- n It is recommended to use a cooling lubricant

TOOL VERSIONS

Order No.	Tool holder designation	Basic shaft [mm]	Dimensions [mm]								Angle [°]		Including shaft adapter [mm]
			a	b	c	d	e	f	g	x	+w	-w	
31002893	520-10R	10 x 10	10	10	118.5	20	36	25	17.5	9	90	-	12 x 12 16 x 16
31002857	520-16U	16 x 16	16	16	123.5	24	42	30	20	13.5	90	90	20 x 20 25 x 25

Sets delivered without diamond tip

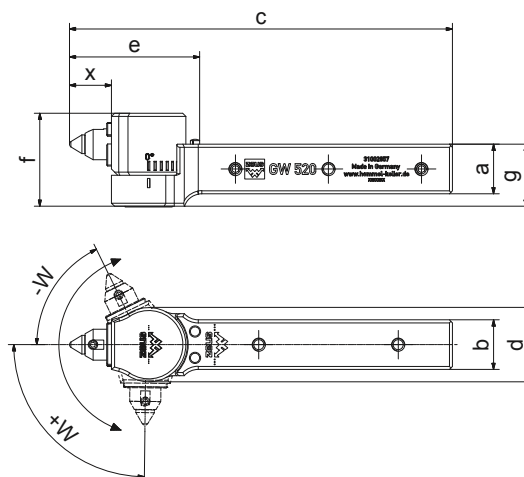
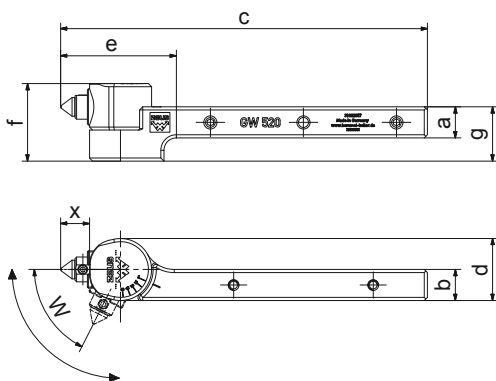

DIAMOND TIP VERSIONS

Order No.	Tip radii [mm]
06TGW0008	0.4
06TGW0009	0.6
06TGW0010	0.8
06TGW0011	1.0

