

# THREADING & GROOVING TOOLS

Metric

## EROJET IS A CUTTING TOOLS MANUFACTURER OF THREAD MILLING, THREAD TURNING AND GROOVING TOOLS

EROJET's tools reputation is built by advanced manufacturing processes with the high professionalism, efficiently and reliably, that's **certified according to ISO 9001**.

EROJET provides the right solution for specific needs, with outstanding customer service, Technical consultation and fast delivery.

## INSERTS ORDERING CODE

ISO	1.5		ER	16	V	K420C
PROFILE	PITCH	MULTITOOTH	TYPE OF INSERT	INSERT SIZE	VERTICAL	CARBIDE GRADES
<b>Partial Profile</b>	<b>Partial Profile</b>	2M		L   I.C.	VERTICAL	K420C K325C K200
60°	MM   TPI	3M	ER= EX. R.H. EL= EX. L.H.	06   4.00		
55°	A   0.5-1.5   48-16			08   5.00		
<b>Full Profile</b>	G   1.75-3.0   14-8		IR= IN. R.H. IL = IN. L.H.	11   6.35		
ISO METRIC	AG   0.5-3.0   48-8			16   9.525		
UN	N   3.5-5.0   7-5			22   12.70		
WHITWORTH	Q   5.5-6.0   4.5-4			27   15.875		
BSPT	<b>Full Profile</b>			33   19.05		
MJ	MM   TPI					
NPT	0.35-6.0   72-4					
NPTF						
TRAPEZ						
ACME						
STUB ACME						
AM. BUTTRESS						
ROUND (DIN 405)						
DIN 20400						
PG						
SAGENGEWINDE						
UNJ						
API						
API ROUND						
BUT. CASING						
EXTREME LINE						

## PARTIAL PROFILE 60° EXTERNAL

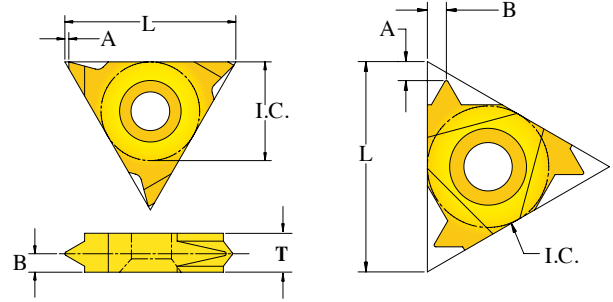
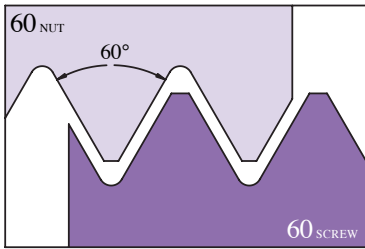

VERTICAL

STANDARD

### STANDARD

PITCH RANGE		CATALOG NUMBER		DIMENSIONS			
MM	TPI	RIGHT HAND	LEFT HAND	L mm	I.C.	A	B
0.5-1.5	48-16	A60 ER11	A60 EL11	11	6.35	0.8	0.9
0.5-1.5	48-16	A60 ER16	A60 EL16	16	9.525	0.8	0.9
1.75-3.0	14-8	G60 ER16	G60 EL16			1.2	1.7
0.5-3.0	48-8	AG60 ER16	AG60 EL16			1.2	1.7
3.5-5.0	7-5	N60 ER22	N60 EL22	22	12.70	1.7	2.5
5.5-6.0	4.5-4	Q60 ER27	Q60 EL27	27	15.875	2.0	3.0

### VERTICAL INSERTS

PITCH RANGE		CATALOG NUMBER	DIMENSIONS				
MM	TPI	RIGHT HAND	L mm	I.C.	A	B	T
0.5-1.5	48-16	A60 ER16V	16	9.525	1.1	1.0	3.7
1.75-3.0	14-8	G60 ER16V			1.1	1.7	3.7
0.5-3.0	48-8	AG60 ER16V			1.1	1.7	3.7

## PARTIAL PROFILE 60° INTERNAL

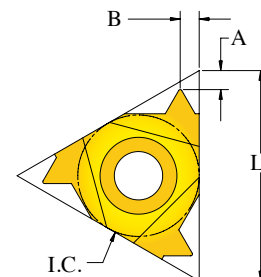
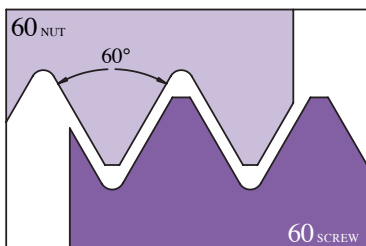

PITCH RANGE		CATALOG NUMBER		DIMENSIONS			
MM	TPI	RIGHT HAND	LEFT HAND	L mm	I.C.	A	B
0.5-1.25	48-20	A60 IR06	A60 IL06	06	4.00	0.5	0.6
0.5-1.5	48-16	A60 IR08	A60 IL08	08	5.00	0.5	0.7
0.5-1.5	48-16	A60 IR11	A60 IL11	11	6.35	0.8	0.9
0.5-1.5	48-16	A60 IR16	A60 IL16	16	9.525	0.8	0.9
1.75-3.0	14-8	G60 IR16	G60 IL16			1.2	1.7
0.5-3.0	48-8	AG60 IR16	AG60 IL16			1.2	1.7
3.5-5.0	7-5	N60 IR22	N60 IL22	22	12.70	1.7	2.5
5.5-6.0	4.5-4	Q60 IR27	Q60 IL27	27	15.875	2.0	3.0

### PARTIAL PROFILE

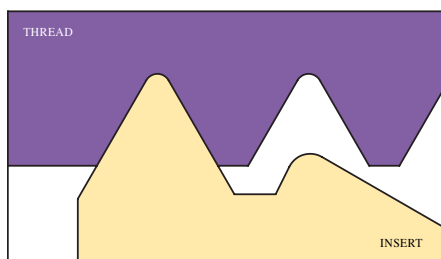

Partial profile use for thread turning without topping. Same insert can be used for wide range of pitches.

## PARTIAL PROFILE 55° EXTERNAL

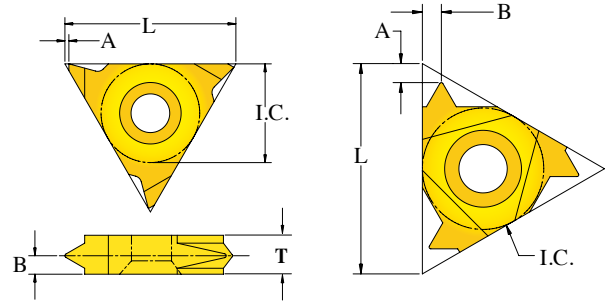
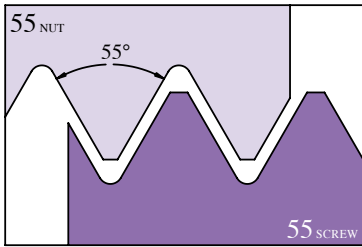

### STANDARD

PITCH RANGE		CATALOG NUMBER		DIMENSIONS			
MM	TPI	RIGHT HAND	LEFT HAND	L mm	I.C.	A	B
0.5-1.5	48-16	A55 ER11	A55 EL11	11	6.35	0.8	0.9
0.5-1.5	48-16	A55 ER16	A55 EL16	16	9.525	0.8	0.9
1.75-3.0	14-8	G55 ER16	G55 EL16			1.2	1.7
0.5-3.0	48-8	AG55 ER16	AG55 EL16			1.2	1.7
3.5-5.0	7-5	N55 ER22	N55 EL22	22	12.70	1.7	2.5
5.5-6.0	4.5-4	Q55 ER27	Q55 EL27	27	15.875	2.1	3.0

### VERTICAL INSERTS

PITCH RANGE		CATALOG NUMBER		DIMENSIONS				
MM	TPI	RIGHT HAND		L mm	I.C.	A	B	T
0.5-1.5	48-16	A55 ER16V		16	9.525	1.1	1.0	3.7
1.75-3.0	14-8	G55 ER16V				1.1	1.7	3.7
0.5-3.0	48-8	AG55 ER16V				1.1	1.7	3.7

## PARTIAL PROFILE 55° INTERNAL

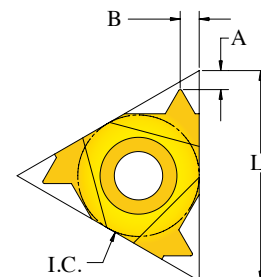
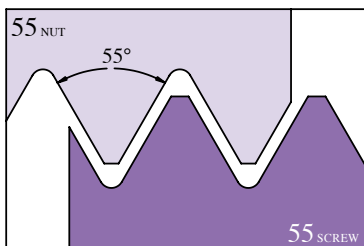

PITCH RANGE		CATALOG NUMBER		DIMENSIONS			
MM	TPI	RIGHT HAND	LEFT HAND	L mm	I.C.	A	B
0.5-1.25	48-20	A55 IR06	A55 IL06	06	4.00	0.5	0.6
0.5-1.5	48-16	A55 IR08	A55 IL08	08	5.00	0.5	0.7
0.5-1.5	48-16	A55 IR11	A55 IL11	11	6.35	0.8	0.9
0.5-1.5	48-16	A55 IR16	A55 IL16	16	9.525	0.8	0.9
1.75-3.0	14-8	G55 IR16	G55 IL16			1.2	1.7
0.5-3.0	48-8	AG55 IR16	AG55 IL16			1.2	1.7
3.5-5.0	7-5	N55 IR22	N55 IL22	22	12.70	1.7	2.5
5.5-6.0	4.5-4	Q55 IR27	Q55 IL27	27	15.875	2.1	3.0

### FULL PROFILE

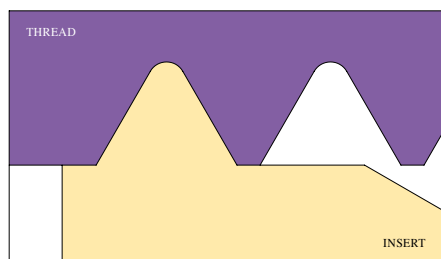

Full profile insert cuts thread profile including all three thread diameters. Separate insert required for every pitch

## ISO METRIC EXTERNAL

ISO 965-1:1999-11

DIN13 : 2005-08

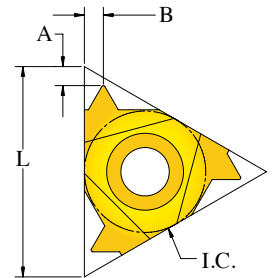
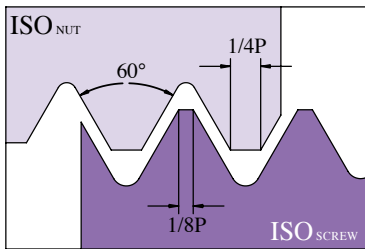

PITCH MM	CATALOG NUMBER		DIMENSIONS			
	RIGHT HAND	LEFT HAND	L mm	I.C.	A	B
0.35	ISO 0.35 ER11	ISO 0.35 EL11	11	6.35	0.7	0.4
0.4	ISO 0.4 ER11	ISO 0.4 EL11			0.6	0.4
0.45	ISO 0.45 ER11	ISO 0.45 EL11			0.6	0.4
0.5	ISO 0.5 ER11	ISO 0.5 EL11			0.6	0.4
0.6	ISO 0.6 ER11	ISO 0.6 EL11			0.6	0.4
0.7	ISO 0.7 ER11	ISO 0.7 EL11			0.6	0.4
0.75	ISO 0.75 ER11	ISO 0.75 EL11			0.6	0.6
0.8	ISO 0.8 ER11	ISO 0.8EL11			0.6	0.6
1.0	ISO 1.0 ER11	ISO 1.0 EL11			0.7	0.7
1.25	ISO 1.25 ER11	ISO 1.25 EL11			0.8	0.9
1.5	ISO 1.5 ER11	ISO 1.5 EL11			0.8	1.0
1.75	ISO 1.75 ER11	ISO 1.75 EL11			0.8	1.1
2.0	ISO 2.0 ER11	ISO 2.0 EL11			0.8	1.1
0.35	ISO 0.35 ER16	ISO 0.35 EL16			16	9.525
0.4	ISO 0.4 ER16	ISO 0.4 EL16	0.8	0.4		
0.45	ISO 0.45 ER16	ISO 0.45 EL16	0.8	0.4		
0.5	ISO 0.5 ER16	ISO 0.5 EL16	0.6	0.4		
0.6	ISO 0.6 ER16	ISO 0.6 EL16	0.6	0.6		
0.7	ISO 0.7 ER16	ISO 0.7 EL16	0.6	0.6		

continued on next page

## ISO METRIC EXTERNAL

ISO 965-1:1999-11

DIN13 : 2005-08

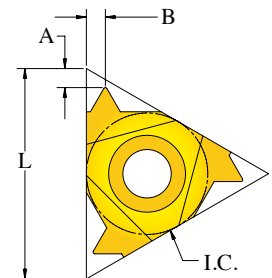
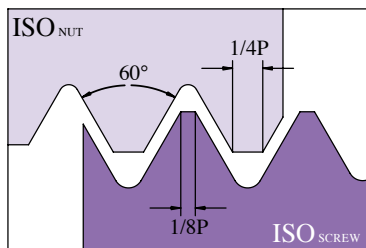

PITCH MM	CATALOG NUMBER		DIMENSIONS			
	RIGHT HAND	LEFT HAND	L mm	I.C.	A	B
0.75	ISO 0.75 ER16	ISO 0.75 EL16	16	9.525	0.6	0.6
0.8	ISO 0.8 ER16	ISO 0.8 EL16			0.6	0.6
1.0	ISO 1.0 ER16	ISO 1.0 EL16			0.7	0.7
1.25	ISO 1.25 ER16	ISO 1.25 EL16			0.8	0.9
1.5	ISO 1.5 ER16	ISO 1.5 EL16			0.8	1.0
1.75	ISO 1.75 ER16	ISO 1.75 EL16			0.9	1.2
2.0	ISO 2.0 ER16	ISO 2.0 EL16			1.0	1.3
2.5	ISO 2.5 ER16	ISO 2.5 EL16			1.1	1.5
3.0	ISO 3.0 ER16	ISO 3.0 EL16			1.2	1.5
3.5	ISO 3.5 ER16	ISO 3.5 EL16			1.2	1.8
3.5	ISO 3.5 ER22	ISO 3.5 EL22	22	12.70	1.6	2.3
4.0	ISO 4.0 ER22	ISO 4.0 EL22			1.6	2.3
4.5	ISO 4.5 ER22	ISO 4.5 EL22			1.7	2.4
5.0	ISO 5.0 ER22	ISO 5.0 EL22			1.7	2.5
5.5	ISO 5.5 ER27	ISO 5.5 EL27	27	15.875	1.8	2.6
6.0	ISO 6.0 ER27	ISO 6.0 EL27			1.9	2.7



## ISO METRIC EXTERNAL

ISO 965-1:1999-11

DIN13 : 2005-08

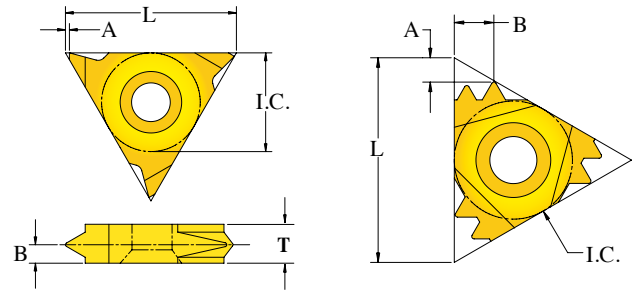
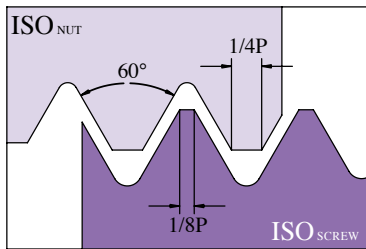

VERTICAL

MULTITOOTH

## MULTITOOTH

PITCH MM	TEETH	CATALOG NUMBER RIGHT HAND	ANVIL	DIMENSIONS			
				L mm	I.C.	A	B
1.0	3	ISO1.0 3M ER16	ES16M	16	9.525	1.6	2.6
1.5	2	ISO1.5 2M ER16				1.6	2.4
1.5	3	ISO1.5 3M ER22	ES22M	22	12.70	2.2	3.8
2.0	2	ISO2.0 2M ER22				2.1	2.9
2.0	3	ISO2.0 3M ER22				3.0	4.9
2.5	2	ISO2.5 2M ER22				2.5	3.8
3.0	2	ISO3.0 2M ER27	ES27M	27	15.875	2.8	4.4

## VERTICAL INSERTS

PITCH MM	CATALOG NUMBER RIGHT HAND	DIMENSIONS				
		L mm	I.C.	A	B	T
1.0	ISO1.0 ER16V	16	9.525	1.1	0.6	3.7
1.25	ISO1.25 ER16V			1.1	0.9	3.7
1.5	ISO1.5 ER16V			1.1	1.0	3.7
2.0	ISO2.0 ER16V			1.1	1.2	3.7

## ISO METRIC INTERNAL

ISO 965-1:1999-11

DIN13 : 2005-08

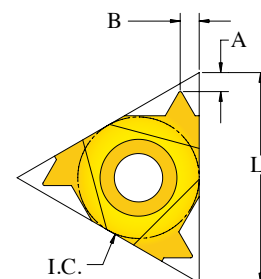
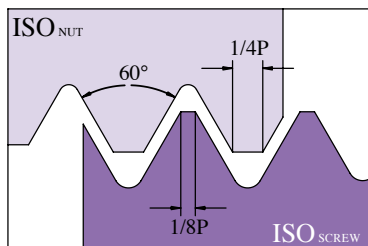

PITCH MM	CATALOG NUMBER		DIMENSIONS			
	RIGHT HAND	LEFT HAND	L mm	I.C.	A	B
0.5	ISO 0.5 IR06	ISO 0.5 IL06	06	4.00	0.8	0.4
0.75	ISO 0.75 IR06	ISO 0.75 IL06			0.7	0.4
1.0	ISO 1.0 IR06	ISO 1.0 IL06			0.7	0.5
1.25	ISO 1.25 IR06	ISO 1.25 IL06			0.7	0.6
0.35	ISO 0.35 IR08	ISO 0.35 IL08	08	5.00	0.7	0.4
0.5	ISO 0.5 IR08	ISO 0.5 IL08			0.7	0.4
0.75	ISO 0.75 IR08	ISO 0.75 IL08			0.7	0.6
1.0	ISO 1.0 IR08	ISO 1.0 IL08			0.7	0.7
1.25	ISO 1.25 IR08	ISO 1.25 IL08			0.7	0.7
1.5	ISO 1.5 IR08	ISO 1.5 IL08			0.7	0.7
1.75	ISO 1.75 IR08	ISO 1.75 IL08	11	6.35	0.7	0.4
0.35	ISO 0.35 IR11	ISO 0.35 IL11			0.7	0.4
0.4	ISO 0.4 IR11	ISO 0.4 IL11			0.7	0.4
0.45	ISO 0.45 IR11	ISO 0.45 IL11			0.7	0.4
0.5	ISO 0.5 IR11	ISO 0.5 IL11			0.6	0.4
0.6	ISO 0.6 IR11	ISO 0.6 IL11			0.6	0.6
0.7	ISO 0.7 IR11	ISO 0.7 IL11			0.6	0.6
0.75	ISO 0.75 IR11	ISO 0.75 IL11			0.6	0.6
0.8	ISO 0.8 IR11	ISO 0.8 IL11			0.6	0.6
1.0	ISO 1.0 IR11	ISO 1.0 IL11			0.7	0.7
1.25	ISO 1.25 IR11	ISO 1.25 IL11			0.8	0.9
1.5	ISO 1.5 IR11	ISO 1.5 IL11			0.8	1.0
1.75	ISO 1.75 IR11	ISO 1.75 IL11	0.8	1.1		
2.0	ISO 2.0 IR11	ISO 2.0 IL11	0.8	0.9		

## ISO METRIC INTERNAL

ISO 965-1:1999-11

DIN13 : 2005-08

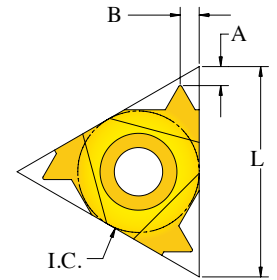
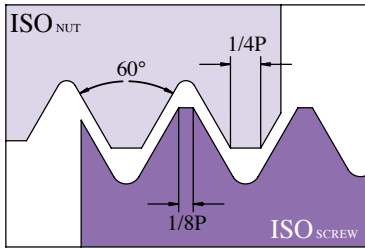

PITCH MM	CATALOG NUMBER		DIMENSIONS			
	RIGHT HAND	LEFT HAND	L mm	I.C.	A	B
0.35	ISO 0.35 IR16	ISO 0.35 IL16	16	9.525	0.8	0.4
0.4	ISO 0.4 IR16	ISO 0.4 IL16			0.8	0.4
0.45	ISO 0.45 IR16	ISO 0.45 IL16			0.8	0.4
0.5	ISO 0.5 IR16	ISO 0.5 IL16			0.6	0.4
0.6	ISO 0.6 IR16	ISO 0.6 IL16			0.6	0.6
0.7	ISO 0.7 IR16	ISO 0.7 IL16			0.6	0.6
0.75	ISO 0.75 IR16	ISO 0.75 IL16			0.6	0.6
0.8	ISO 0.8 IR16	ISO 0.8 IL16			0.6	0.6
1.0	ISO 1.0 IR16	ISO 1.0 IL16			0.7	0.7
1.25	ISO 1.25 IR16	ISO 1.25 IL16			0.8	0.9
1.5	ISO 1.5 IR16	ISO 1.5 IL16			0.8	1.0
1.75	ISO 1.75 IR16	ISO 1.75 IL16			0.9	1.2
2.0	ISO 2.0 IR16	ISO 2.0 IL16			1.0	1.3
2.5	ISO 2.5 IR16	ISO 2.5 IL16			1.1	1.5
3.0	ISO 3.0 IR16	ISO 3.0 IL16			1.2	1.5
3.5	ISO 3.5 IR16	ISO 3.5 IL16			1.2	1.8

## ISO METRIC INTERNAL

ISO 965-1:1999-11

DIN13 : 2005-08

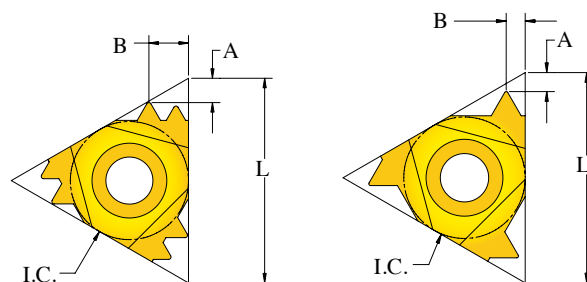
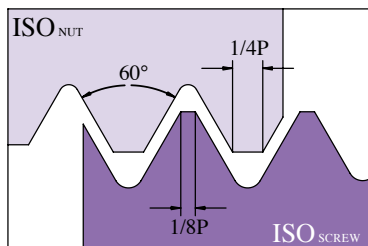

## STANDARD

MULTITOOTH

STANDARD

PITCH MM	CATALOG NUMBER		DIMENSIONS			
	RIGHT HAND	LEFT HAND	L mm	I.C.	A	B
3.5	ISO 3.5 IR22	ISO 3.5 IL22	22	12.70	1.6	2.3
4.0	ISO 4.0 IR22	ISO 4.0 IL22			1.6	2.3
4.5	ISO 4.5 IR22	ISO 4.5 IL22			1.7	2.4
5.0	ISO 5.0 IR22	ISO 5.0 IL22			1.7	2.5
5.5	ISO 5.5 IR27	ISO 5.5 IL27	27	15.875	1.8	2.4
6.0	ISO 6.0 IR27	ISO 6.0 IL27			1.9	2.6

## MULTITOOTH

PITCH MM	TEETH	CATALOG NUMBER RIGHT HAND	ANVIL	DIMENSIONS			
				L mm	I.C.	A	B
1.0	3	ISO1.0 3M IR16	IS16M	16	9.525	1.6	2.6
1.5	2	ISO1.5 2M IR16				1.6	2.4
1.5	3	ISO1.5 3M IR22	IS22M	22	12.70	2.2	3.8
2.0	2	ISO2.0 2M IR22				2.1	2.9
2.0	3	ISO2.0 3M IR22				3.0	4.9
3.0	2	ISO3.0 2M IR27	IS27M	27	15.875	2.8	4.4

## UN

(UNC, UNF, UNEF)

### EXTERNAL

ANSI B1.1-1982

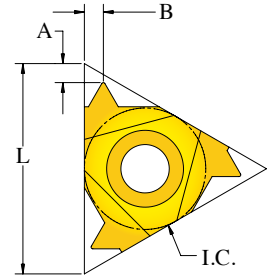
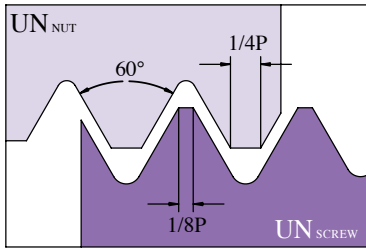

PITCH	CATALOG NUMBER		DIMENSIONS			
	RIGHT HAND	LEFT HAND	L mm	I.C.	A	B
72	UN 72 ER11	UN 72 EL11	11	6.35	0.8	0.4
64	UN 64 ER11	UN 64 EL11			0.8	0.4
56	UN 56 ER11	UN 56 EL11			0.8	0.4
48	UN 48 ER11	UN 48 EL11			0.6	0.6
44	UN 44 ER11	UN 44 EL11			0.6	0.6
40	UN 40 ER11	UN 40 EL11			0.6	0.6
36	UN 36 ER11	UN 36 EL11			0.6	0.6
32	UN 32 ER11	UN 32 EL11			0.6	0.6
28	UN 28 ER11	UN 28 EL11			0.6	0.7
27	UN 27 ER11	UN 27EL11			0.6	0.7
24	UN 24 ER11	UN 24 EL11			0.7	0.8
20	UN 20 ER11	UN 20 EL11			0.8	0.9
18	UN 18 ER11	UN 18 EL11			0.8	1.0
16	UN 16 ER11	UN 16 EL11			0.9	1.1
14	UN 14 ER11	UN 14 EL11			0.9	1.1
13	UN 13 ER11	UN 13 EL11	0.9	1.1		
72	UN 72 ER16	UN 72 EL16	16	9.525	0.8	0.4
64	UN 64 ER16	UN 64 EL16			0.8	0.4
56	UN 56 ER16	UN 56 EL16			0.8	0.4
48	UN 48 ER16	UN 48 EL16			0.6	0.6
44	UN 44 ER16	UN 44 EL16			0.6	0.6
40	UN 40 ER16	UN 40 EL16			0.6	0.6

continued on next page

## UN

(UNC, UNF, UNEF)

### EXTERNAL

ANSI B1.1-1982

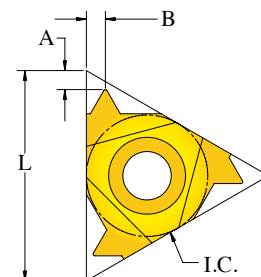
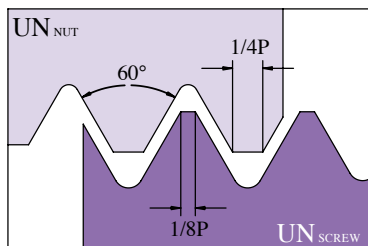

PITCH	CATALOG NUMBER		DIMENSIONS			
	RIGHT HAND	LEFT HAND	L mm	I.C.	A	B
36	UN 36 ER16	UN 36 EL16	16	9.525	0.6	0.6
32	UN 32 ER16	UN 32 EL16			0.6	0.6
28	UN 28 ER16	UN 28 EL16			0.6	0.7
27	UN 27 ER16	UN 27EL16			0.7	0.8
24	UN 24 ER16	UN 24 EL16			0.7	0.8
20	UN 20 ER16	UN 20 EL16			0.8	0.9
18	UN 18 ER16	UN 18 EL16			0.8	1.0
16	UN 16 ER16	UN 16 EL16			0.9	1.1
14	UN 14 ER16	UN 14 EL16			1.0	1.2
13	UN 13 ER16	UN 13 EL16			1.0	1.3
12	UN 12 ER16	UN 12 EL16			1.1	1.4
11	UN 11 ER16	UN 11 EL16			1.1	1.5
10	UN 10 ER16	UN 10 EL16			1.1	1.5
9	UN 9 ER16	UN 9 EL16			1.2	1.7
8	UN 8 ER16	UN 8 EL16			1.2	1.6
7	UN 7 ER22	UN 7 EL22			22	12.70
6	UN 6 ER22	UN 6 EL22	1.6	2.3		
5	UN 5 ER22	UN 5 EL22	1.7	2.5		
4.5	UN 4.5 ER27	UN 4.5EL27	27	15.875	1.8	2.6
4	UN 4 ER27	UN 4 EL27			2.1	2.9

## UN

(UNC, UNF, UNEF)

### EXTERNAL

ANSI B1.1-1982

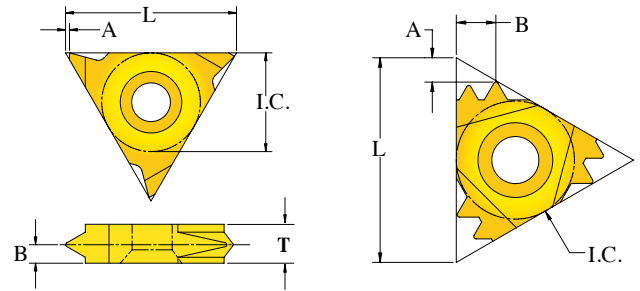
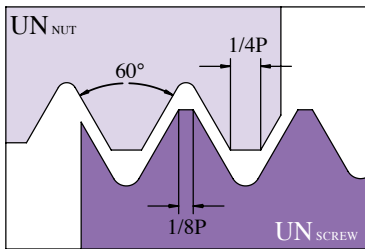

VERTICAL

MULTITOOTH

### MULTITOOTH

PITCH TPI	TEETH	CATALOG NUMBER RIGHT HAND	ANVIL	DIMENSIONS			
				L mm	I.C.	A	B
20	2	UN20 2M ER16	ES16M	16	9.525	1.4	2.1
16	2	UN16 2M ER16				1.6	2.4
14	2	UN14 2M ER16				1.8	2.7
16	3	UN16 3M ER22	ES22M	22	12.70	2.5	4.1
12	2	UN12 2M ER22				2.1	3.3
12	3	UN12 3M ER22				3.2	5.2
8	2	UN8 2M ER27	ES27M	27	15.875	3.1	4.8

### VERTICAL INSERTS

PITCH TPI	CATALOG NUMBER RIGHT HAND	DIMENSIONS				
		L mm	I.C.	A	B	T
20	UN20 ER16V	16	9.525	1.1	0.8	3.7
16	UN16 ER16V			1.1	1.0	3.7
14	UN14 ER16V			1.1	1.2	3.7
12	UN12 ER16V			1.1	1.3	3.7

## UN

(UNC, UNF, UNEF)

### INTERNAL

ANSI B1.1-1982

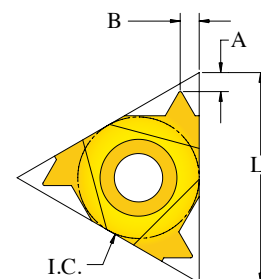
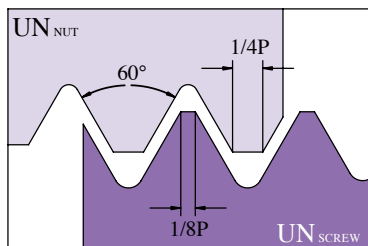

PITCH	CATALOG NUMBER		DIMENSIONS			
	RIGHT HAND	LEFT HAND	L mm	I.C.	A	B
40	UN 40 IR06	UN 40 IL06	06	4.00	0.7	0.5
36	UN 36 IR06	UN 36 IL06			0.7	0.5
32	UN 32 IR06	UN 32 IL06			0.7	0.6
28	UN 28 IR06	UN 28 IL06			0.7	0.7
24	UN 24 IR06	UN 24 IL06			0.7	0.7
20	UN 20 IR06	UN 20 IL06			0.7	0.7
18	UN 18 IR06	UN 18 IL06			0.7	0.7
40	UN 40 IR08	UN 40 IL08			08	5.00
36	UN 36 IR08	UN 36 IL08	0.7	0.5		
32	UN 32 IR08	UN 32 IL08	0.7	0.6		
28	UN 28 IR08	UN 28 IL08	0.7	0.7		
24	UN 24 IR08	UN 24 IL08	0.7	0.7		
20	UN 20 IR08	UN 20 IL08	0.7	0.7		
18	UN 18 IR08	UN 18 IL08	0.7	0.7		
16	UN 16 IR08	UN 16 IL08	0.7	0.7		
14	UN 14 IR08	UN 14 IL08	0.7	0.7		



## UN

(UNC, UNF, UNEF)

### INTERNAL

ANSI B1.1-1982

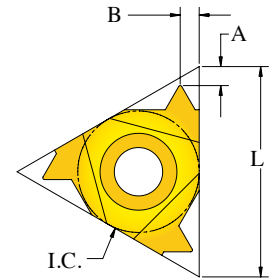
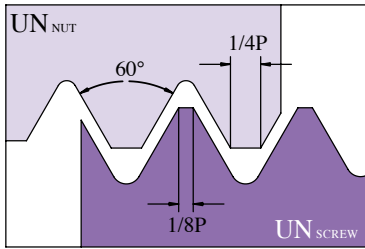

PITCH TPI	CATALOG NUMBER		DIMENSIONS			
	RIGHT HAND	LEFT HAND	L mm	I.C.	A	B
72	UN 72 IR11	UN 72 IL11	11	6.35	0.6	0.6
64	UN 64 IR11	UN 64 IL11			0.6	0.7
56	UN 56 IR11	UN 56 IL11			0.6	0.6
48	UN 48 IR11	UN 48 IL11			0.6	0.7
44	UN 44 IR11	UN 44 IL11			0.6	0.7
40	UN 40 IR11	UN 40 IL11			0.6	0.6
36	UN 36 IR11	UN 36 IL11			0.6	0.7
32	UN 32 IR11	UN 32 IL11			0.6	0.6
28	UN 28 IR11	UN 28 IL11			0.6	0.7
27	UN 27IR11	UN 27IL11			0.6	0.7
24	UN 24 IR11	UN 24 IL11			0.7	0.8
20	UN 20 IR11	UN 20 IL11			0.8	0.9
18	UN 18 IR11	UN 18 IL11			0.8	1.0
16	UN 16 IR11	UN 16 IL11			0.6	1.1
14	UN 14 IR11	UN 14 IL11			0.6	1.1
13	UN 13 IR11	UN 13 IL11			0.6	1.0
12	UN 12 IR11	UN 12 IL11			0.6	1.1
11	UN 11 IR11	UN 11 IL11			0.8	1.1

## UN

(UNC, UNF, UNEF)

### INTERNAL

ANSI B1.1-1982

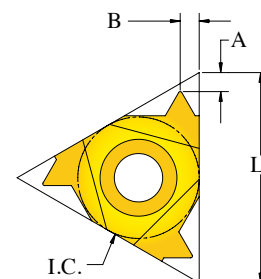
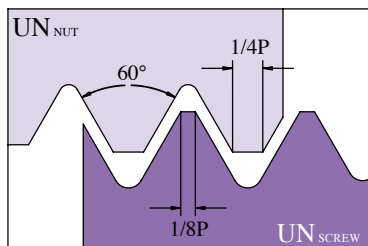

PITCH TPI	CATALOG NUMBER		DIMENSIONS			
	RIGHT HAND	LEFT HAND	L mm	I.C.	A	B
72	UN 72 IR16	UN 72 IL16	16	9.525	0.6	0.6
64	UN 64 IR16	UN 64 IL16			0.6	0.7
56	UN 56 IR16	UN 56 IL16			0.6	0.6
48	UN 48 IR16	UN 48 IL16			0.6	0.7
44	UN 44 IR16	UN 44 IL16			0.6	0.7
40	UN 40 IR16	UN 40 IL16			0.6	0.6
36	UN 36 IR16	UN 36 IL16			0.6	0.7
32	UN 32 IR16	UN 32 IL16			0.6	0.6
28	UN 28 IR16	UN 28 IL16			0.6	0.7
27	UN 27IR16	UN 27IL16			0.6	0.7
24	UN 24 IR16	UN 24 IL16			0.7	0.8
20	UN 20 IR16	UN 20 IL16			0.8	0.9
18	UN 18 IR16	UN 18 IL16			0.8	1.0
16	UN 16 IR16	UN 16 IL16			0.6	1.1
14	UN 14 IR16	UN 14 IL16			1.0	1.2
13	UN 13 IR16	UN 13 IL16			1.0	1.3
12	UN 12 IR16	UN 12 IL16			1.1	1.4
11	UN 11 IR16	UN 11 IL16			1.1	1.5
10	UN 10 IR16	UN 10 IL16			1.1	1.5
9	UN 9 IR16	UN 9 IL16			1.2	1.7
8	UN 8 IR16	UN 8 IL16	1.2	1.6		

## UN

(UNC, UNF, UNEF)

### INTERNAL

ANSI B1.1-1982

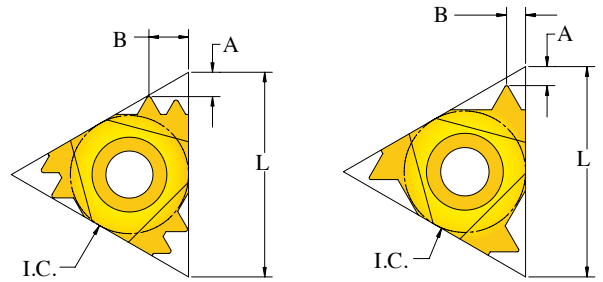
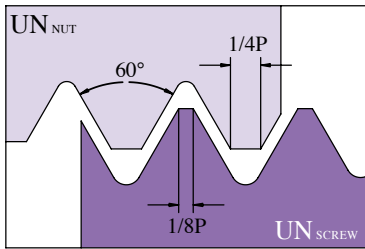

MULTITOOTH

STANDARD

### STANDARD

PITCH TPI	CATALOG NUMBER		DIMENSIONS			
	RIGHT HAND	LEFT HAND	L mm	I.C.	A	B
7	UN 7 IR22	UN 7 IL22	22	12.70	1.6	2.3
6	UN 6 IR22	UN 6 IL22			1.6	2.3
5	UN 5 IR22	UN 5 IL22			1.7	2.4
4.5	UN 4.5 IR27	UN 4.5 IL27	27	15.875	1.8	2.6
4	UN 4 IR27	UN 4 IL27			2.0	2.8

### MULTITOOTH

PITCH TPI	TEETH	CATALOG NUMBER RIGHT HAND	ANVIL	DIMENSIONS			
				L mm	I.C.	A	B
20	2	UN20 2M IR16	IS16M	16	9.525	1.6	2.6
16	2	UN16 2M IR16				1.6	2.4
14	2	UN14 2M IR16				2.2	3.8
12	2	UN12 2M IR16				2.1	2.6
16	3	UN16 3M IR22	IS22M	22	12.70	3.0	4.6
12	2	UN12 2M IR22				2.5	3.7
12	3	UN12 3M IR22				3.4	5.2
8	2	UN8 2M IR27	IS27M	27	15.875	2.8	4.4

## WHITWORTH

BSW, BSF, BSP

**EXTERNAL**

B.S.84: 1956

ISO 228-1: 1994

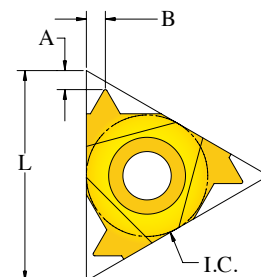
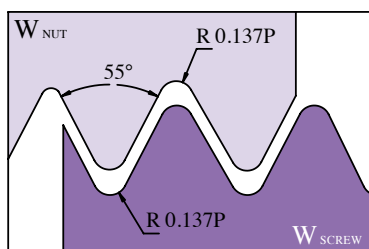

PITCH	CATALOG NUMBER		DIMENSIONS			
	RIGHT HAND	LEFT HAND	L mm	I.C.	A	B
72	W72 ER11	W72 EL11	11	6.35	0.6	0.4
60	W60 ER11	W60 EL11			0.6	0.4
56	W56 ER11	W56 EL11			0.6	0.4
48	W48 ER11	W48 EL11			0.6	0.6
40	W 40 ER11	W 40 EL11			0.6	0.6
36	W36 ER11	W36 EL11			0.6	0.6
32	W 32 ER11	W 32 EL11			0.6	0.6
28	W 28 ER11	W 28 EL11			0.6	0.7
26	W 26 ER11	W 26 EL11			0.7	0.8
24	W 24 ER11	W 24 EL11			0.7	0.8
22	W 22 ER11	W 22 EL11			0.8	0.9
20	W 20 ER11	W 20 EL11			0.8	0.9
19	W 19 ER11	W 19 EL11			0.8	1.0
18	W 18 ER11	W 18 EL11			0.8	1.0
16	W 16 ER11	W 16 EL11			0.9	1.1
14	W 14 ER11	W 14 EL11			0.9	1.0
72	W72 ER16	W72 EL16	16	9.525	0.7	0.4
60	W60 ER16	W60 EL16			0.7	0.4
56	W56 ER16	W56 EL16			0.7	0.4
48	W48 ER16	W48 EL16			0.6	0.6
40	W 40 ER16	W 40 EL16			0.6	0.6
36	W 36 ER16	W 36 EL16			0.6	0.6

continued on next page

## WHITWORTH

BSW, BSF, BSP

**EXTERNAL**

B.S.84: 1956

ISO 228-1: 1994

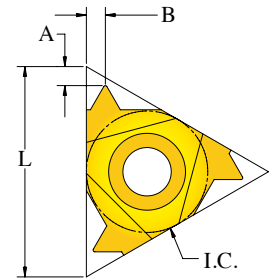
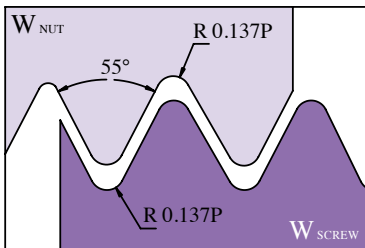

PITCH	CATALOG NUMBER		DIMENSIONS			
	RIGHT HAND	LEFT HAND	L mm	I.C.	A	B
32	W 32 ER16	W 32 EL16	16	9.525	0.6	0.6
28	W 28 ER16	W 28 EL16			0.6	0.7
26	W 26 ER16	W 26 EL16			0.6	0.7
24	W 24 ER16	W 24 EL16			0.7	0.8
22	W 22 ER16	W 22 EL16			0.8	0.9
20	W 20 ER16	W 20 EL16			0.8	0.9
19	W 19 ER16	W 19 EL16			0.8	1.0
18	W 18 ER16	W 18 EL16			0.8	1.0
16	W 16 ER16	W 16 EL16			0.9	1.1
14	W 14 ER16	W 14 EL16			1.0	1.2
12	W 12 ER16	W 12 EL16			1.1	1.4
11	W 11 ER16	W 11 EL16			1.1	1.5
10	W 10 ER16	W 10 EL16			1.1	1.5
9	W 9 ER16	W 9 EL16			1.2	1.7
8	W 8 ER16	W 8 EL16			1.2	1.5
7	W 7 ER22	W 7 EL22			22	12.70
6	W 6 ER22	W 6 EL22	1.6	2.3		
5	W 5 ER22	W 5 EL22	1.7	2.4		
4.5	W 4.5 ER27	W 4.5 EL27	27	15.875	1.7	2.5
4	W 4 ER27	W 4 EL27			1.9	2.8

## WHITWORTH

BSW, BSF, BSP

**EXTERNAL**

B.S.84: 1956

ISO 228-1: 1994

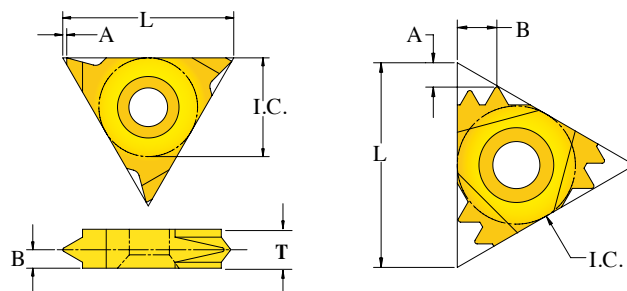
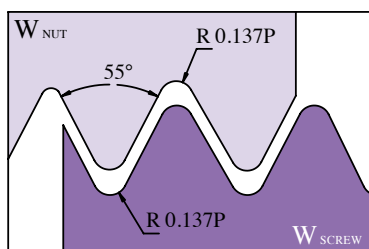

VERTICAL

MULTITOOTH

## MULTITOOTH

PITCH TPI	TEETH	CATALOG NUMBER RIGHT HAND	ANVIL	DIMENSIONS			
				L mm	I.C.	A	B
14	2	W14 2M ER16	ES16M	16	9.525	1.8	2.8
14	3	W14 3M ER22	ES22M	22	12.70	2.8	4.6
11	2	W11 2M ER22				2.4	3.5

## VERTICAL INSERTS

PITCH TPI	CATALOG NUMBER	DIMENSIONS				
	RIGHT HAND	L mm	I.C.	A	B	T
19	W19 ER16V	16	9.525	1.1	0.8	3.7
14	W14 ER16V			1.1	1.1	3.7
11	W11 ER16V			1.1	1.3	3.7

## WHITWORTH

BSW, BSF, BSP

INTERNAL

B.S.84: 1956

ISO 228-1: 1994

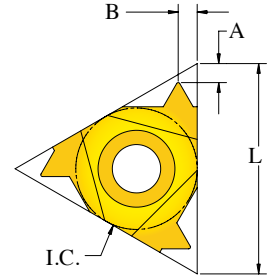
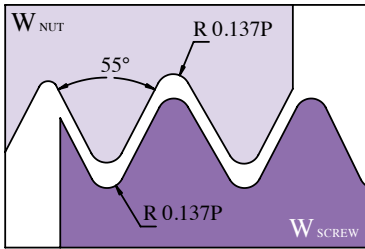

PITCH TPI	CATALOG NUMBER		DIMENSIONS			
	RIGHT HAND	LEFT HAND	L mm	I.C.	A	B
28	W28 IR06	W28 IL06	06	4.00	0.7	0.6
26	W26 IR06	W26 IL06			0.7	0.6
24	W24 IR06	W24 IL06			0.7	0.6
22	W22 IR06	W22 IL06			0.7	0.6
19	W19 IR06	W19 IL06			0.7	0.7
18	W18 IR06	W18 IL06			0.7	0.7
28	W 28 IR08	W 28 IL08	08	5.00	0.7	0.7
26	W 26 IR08	W 26 IL08			0.7	0.7
24	W 24 IR08	W 24 IL08			0.7	0.7
20	W 20 IR08	W 20 IL08			0.7	0.7
19	W 19 IR08	W 19 IL08			0.7	0.7
18	W 18 IR08	W 18 IL08			0.7	0.7
16	W 16 IR08	W 16 IL08			0.7	0.7
72	W 72 IR11	W 72 IL11	11	6.35	0.7	0.4
60	W 60 IR11	W 60 IL11			0.7	0.4
56	W 56 IR11	W 56 IL11			0.7	0.4
48	W 48 IR11	W 48 IL11			0.6	0.6
40	W 40 IR11	W 40 IL11			0.6	0.6
32	W 32 IR11	W 32 IL11			0.6	0.6
28	W 28 IR11	W 28 IL11			0.6	0.7
26	W 26 IR11	W 26 IL11			0.7	0.8
24	W 24 IR11	W 24 IL11			0.7	0.8
20	W 20 IR11	W 20 IL11			0.8	0.9
19	W 19 IR11	W 19 IL11			0.8	1.0
18	W 18 IR11	W 18 IL11			0.8	1.0
16	W 16 IR11	W 16 IL11			0.9	1.1
14	W 14 IR11	W 14 IL11			0.9	1.1

## WHITWORTH

BSW, BSF, BSP

**INTERNAL**

B.S.84: 1956

ISO 228-1: 1994

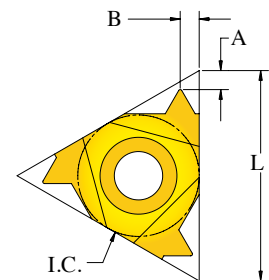
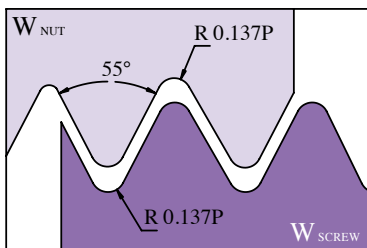

PITCH TPI	CATALOG NUMBER		DIMENSIONS			
	RIGHT HAND	LEFT HAND	L mm	I.C.	A	B
72	W 72 IR16	W 72 IL16	16	9.525	0.7	0.4
60	W 60 IR16	W 60 IL16			0.7	0.4
56	W 56 IR16	W 56 IL16			0.7	0.4
48	W 48 IR16	W 48 IL16			0.6	0.6
40	W 40 IR16	W 40 IL16			0.6	0.6
36	W 36 IR16	W 36 IL16			0.6	0.6
32	W 32 IR16	W 32 IL16			0.6	0.6
28	W 28 IR16	W 28 IL16			0.6	0.7
26	W 26 IR16	W 26 IL16			0.7	0.8
24	W 24 IR16	W 24 IL16			0.7	0.8
22	W 22 IR16	W 22 IL16			0.8	0.9
20	W 20 IR16	W 20 IL16			0.8	1.0
19	W 19 IR16	W 19 IL16			0.8	1.0
18	W 18 IR16	W 18 IL16			0.8	1.0
16	W 16 IR16	W 16 IL16			0.9	1.1
14	W 14 IR16	W 14 IL16			1.0	1.2
12	W 12 IR16	W 12 IL16			1.1	1.4
11	W 11 IR16	W 11 IL16			1.1	1.5
10	W 10 IR16	W 10 IL16			1.1	1.5
9	W 9 IR16	W 9 IL16			1.2	1.7
8	W 8 IR16	W 8 IL16	1.2	1.5		



## WHITWORTH

BSW, BSF, BSP

INTERNAL

B.S.84: 1956

ISO 228-1: 1994

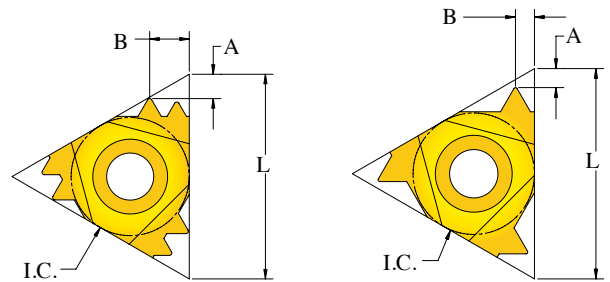
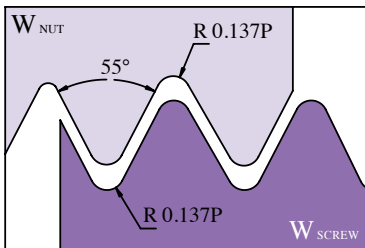

MULTITOOTH

STANDARD

## STANDARD

PITCH TPI	CATALOG NUMBER		DIMENSIONS			
	RIGHT HAND	LEFT HAND	L mm	I.C.	A	B
7	W 7 IR22	W 7 IL22	22	12.70	1.6	2.3
6	W 6 IR22	W 6 IL22			1.6	2.3
5	W 5 IR22	W 5 IL22			1.7	2.4
4.5	W 4.5 IR27	W 4.5 IL27	27	15.875	1.7	2.5
4	W 4 IR27	W 4 IL 27			1.9	2.8

## MULTITOOTH

PITCH TPI	TEETH	CATALOG NUMBER RIGHT HAND	ANVIL	DIMENSIONS			
				L mm	I.C.	A	B
14	2	W14 2M IR16	IS16M	16	9.525	1.8	2.8
14	3	W14 3M IR22	IS22M	22	12.70	2.8	4.6
11	2	W11 2M IR22				2.4	3.5

## PG

DIN 40430 ; 1971

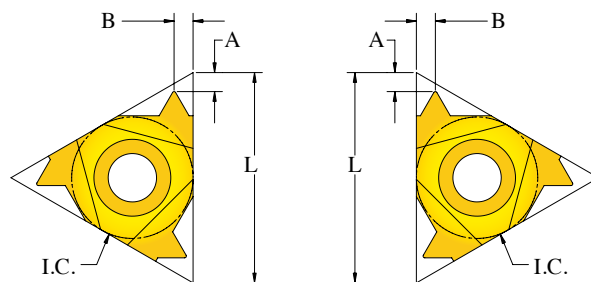
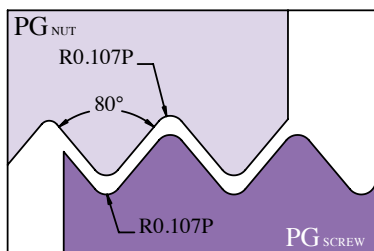

INTERNAL

EXTERNAL

### EXTERNAL

PITCH TPI	SIZE	CATALOG NUMBER RIGHT HAND	DIMENSIONS			
			L mm	I.C.	A	B
20	PG7	PG20 ER11	11	6.35	1.3	0.8
18	PG 9, PG 11, PG 13.5, PG16	PG18 ER11			0.8	0.9
16	PG21, PG29, PG36, PG42, PG48	PG16 ER11			1.0	1.1
20	PG7	PG20 ER16	16	9.525	0.8	0.8
18	PG 9, PG 11, PG 13.5, PG16	PG18 ER16			0.9	1.0
16	PG21, PG29, PG36, PG42, PG48	PG16 ER16			0.9	1.1

### INTERNAL

PITCH TPI	SIZE	CATALOG NUMBER RIGHT HAND	DIMENSIONS			
			L mm	I.C.	A	B
20	PG7	PG20 IR11	11	6.35	1.3	0.8
18	PG 9, PG 11, PG 13.5, PG16	PG18 IR11			0.8	0.9
20	PG7	PG20 IR16			0.8	0.8
18	PG 9, PG 11, PG 13.5, PG16	PG18 IR16	16	9.525	0.8	1.0
16	PG21, PG29, PG36, PG42, PG48	PG16 IR16			0.9	1.1

## BSPT EXTERNAL

B.S. 21: 1985

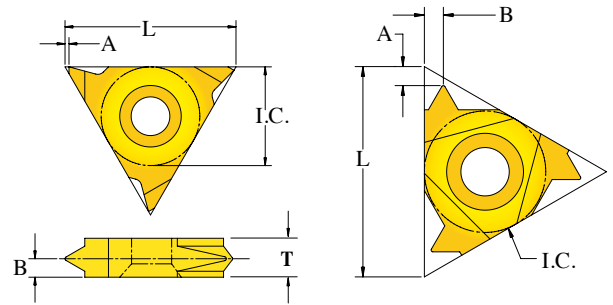
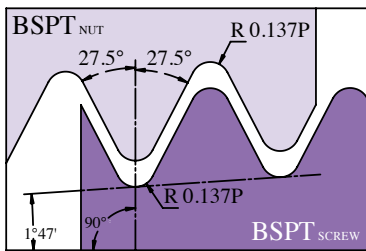

VERTICAL

STANDARD

## STANDARD

PITCH TPI	CATALOG NUMBER		DIMENSIONS			
	RIGHT HAND	LEFT HAND	L mm	I.C.	A	B
28	BSPT 28 ER11	BSPT 28 EL11	11	6.35	0.7	0.6
19	BSPT 19 ER11	BSPT 19 EL11			0.8	0.9
14	BSPT 14 ER11	BSPT 14 EL11			0.9	1.0
28	BSPT 28 ER16	BSPT 28 EL16	16	9.525	0.6	0.6
19	BSPT 19 ER16	BSPT 19 EL16			0.8	0.9
14	BSPT 14 ER16	BSPT 14 EL16			1.0	1.2
11	BSPT 11 ER16	BSPT 11 EL16			1.1	1.5

## VERTICAL INSERTS

PITCH TPI	CATALOG NUMBER		DIMENSIONS				
	RIGHT HAND		L mm	I.C.	A	B	T
28	BSPT28 ER16V		16	9.525	1.1	0.8	3.7
19	BSPT19 ER16V				1.1	1.0	3.7
14	BSPT14 ER16V				1.1	1.2	3.7
11	BSPT11 ER16V				1.1	1.5	3.7

## BSPT INTERNAL

B.S. 21: 1985

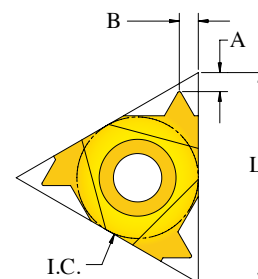
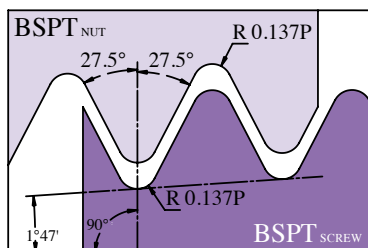

PITCH  TPI	CATALOG NUMBER		DIMENSIONS			
	RIGHT HAND	LEFT HAND	L mm	I.C.	A	B
28	BSPT 28 IR06	BSPT 28 IL06	06	4.00	0.7	0.5
28	BSPT 28 IR08	BSPT 28 IL08	08	5.00	0.7	0.6
19	BSPT 19 IR08	BSPT 19 IL08			0.7	0.7
28	BSPT 28 IR11	BSPT 28 IL11	11	6.35	0.8	0.9
19	BSPT 19 IR11	BSPT 19 IL11			0.8	0.9
14	BSPT 14 IR11	BSPT 14 IL11			0.9	1.0
28	BSPT 28 IR16	BSPT 28 IL16	16	9.525	0.6	0.6
19	BSPT 19 IR16	BSPT 19 IL16			0.8	0.9
14	BSPT 14 IR16	BSPT 14 IL16			1.0	1.2
11	BSPT 11 IR16	BSPT 11 IL16			1.1	1.5

## NPT EXTERNAL

ANSI/ASME B 1.20.1-1983

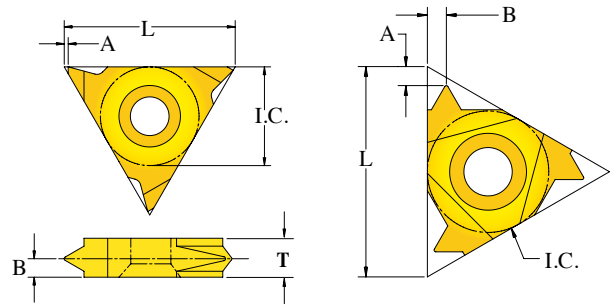
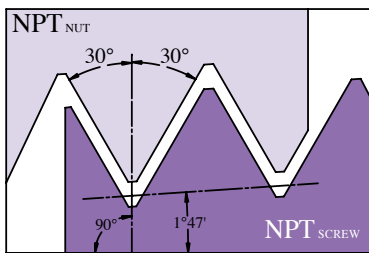

VERTICAL

STANDARD

## STANDARD

PITCH TPI	CATALOG NUMBER		DIMENSIONS			
	RIGHT HAND	LEFT HAND	L mm	I.C.	A	B
27	NPT 27 ER11	NPT 27 EL11	11	6.35	0.7	0.8
18	NPT 18 ER11	NPT 18 EL11			0.8	1.0
14	NPT 14 ER11	NPT 14 EL11			0.8	1.0
27	NPT 27 ER16	NPT 27 EL16	16	9.525	0.7	0.8
18	NPT 18 ER16	NPT 18 EL16			0.8	1.0
14	NPT 14 ER16	NPT 14 EL16			0.9	1.2
11.5	NPT 11.5 ER16	NPT 11.5 EL16			1.1	1.5
8	NPT 8 ER16	NPT 8 EL16			1.3	1.8

## MULTITOOTH

PITCH TPI	TEETH	CATALOG NUMBER RIGHT HAND	ANVIL	DIMENSIONS			
				L mm	I.C.	A	B
11.5	2	NPT11.5 2M ER22	ES22M	22	12.70	2.4	3.4
11.5	3	NPT11.5 3M ER27	ES27M	27	15.875	3.5	5.6
8	2	NPT8 2M ER27				3.0	4.8

## VERTICAL INSERTS

PITCH TPI	CATALOG NUMBER		DIMENSIONS				
	RIGHT HAND		L mm	I.C.	A	B	T
27	NPT27 ER16V		16	9.525	1.1	0.8	3.7
18	NPT18 ER16V				1.1	1.0	3.7
14	NPT14 ER16V				1.1	1.2	3.7
11.5	NPT11.5 ER16V				1.1	1.5	3.7

## NPT INTERNAL

ANSI/ASME B 1.20.1-1983

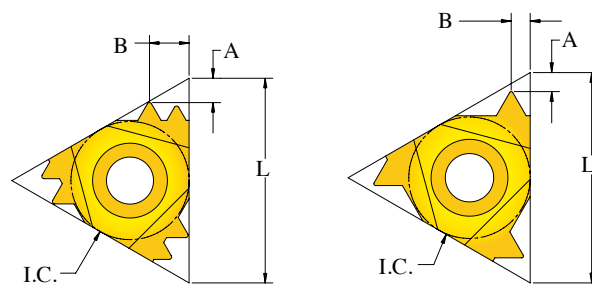
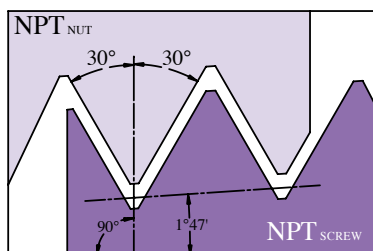

MULTITOOTH

STANDARD

## STANDARD

PITCH TPI	CATALOG NUMBER		DIMENSIONS			
	RIGHT HAND	LEFT HAND	L mm	I.C.	A	B
27	NPT 27 IR06	NPT 27 IL06	06	4.00	0.7	0.5
27	NPT 27 IR08	NPT 27 IL08	08	5.00	0.7	0.6
18	NPT 18 IR08	NPT 18 IL08			0.7	0.7
27	NPT 27 IR11	NPT 27 IL11	11	6.35	0.7	0.8
18	NPT 18 IR11	NPT 18 IL11			0.8	1.0
14	NPT 14 IR11	NPT 14 IL11			0.8	1.0
27	NPT 27 IR16	NPT 27 IL16	16	9.525	0.7	0.8
18	NPT 18 IR16	NPT 18 IL16			0.8	1.0
14	NPT 14 IR16	NPT 14 IL16			0.9	1.2
11.5	NPT 11.5 IR16	NPT 11.5 IL16			1.1	1.5
8	NPT 8 IR16	NPT 8 IL16			1.3	1.8

## MULTITOOTH

PITCH TPI	TEETH	CATALOG NUMBER RIGHT HAND	ANVIL	DIMENSIONS			
				L mm	I.C.	A	B
11.5	2	NPT11.5 2M IR22	IS22M	22	12.70	2.4	3.4
11.5	3	NPT11.5 3M IR27	IS27M	27	15.875	3.5	5.6
8	2	NPT8 2M IR27				3.0	4.8

## NPTF EXTERNAL

ANSI B 1.20.3-1976

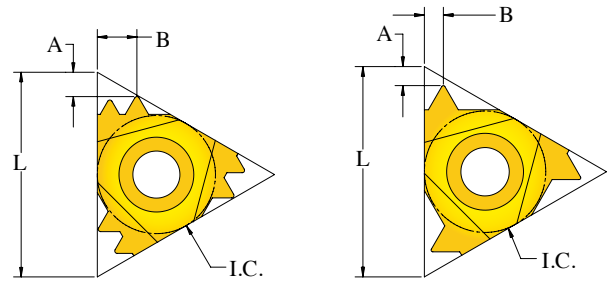
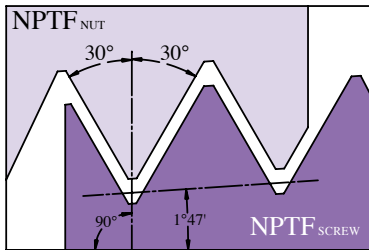

MULTITOOTH

STANDARD

### STANDARD

PITCH TPI	CATALOG NUMBER		DIMENSIONS			
	RIGHT HAND	LEFT HAND	L mm	I.C.	A	B
27	NPTF 27 ER11	NPTF 27 EL11	11	6.35	0.7	0.8
18	NPTF 18 ER11	NPTF 18 EL11			0.8	1.0
14	NPTF 14 ER11	NPTF 14 EL11			0.8	1.0
27	NPTF 27 ER16	NPTF 27 EL16	16	9.525	0.7	0.8
18	NPTF 18 ER16	NPTF 18 EL16			0.8	1.0
14	NPTF 14 ER16	NPTF 14 EL16			0.9	1.2
11.5	NPTF 11.5 ER16	NPTF 11.5 EL16			1.1	1.5
8	NPTF 8 ER16	NPTF 8 EL16			1.3	1.8

### MULTITOOTH

PITCH TPI	TEETH	CATALOG NUMBER RIGHT HAND	ANVIL	DIMENSIONS			
				L mm	I.C.	A	B
11.5	2	NPTF11.5 2M ER22	ES22M	22	12.70	2.4	3.4

## NPTF INTERNAL

ANSI B 1.20.3-1976

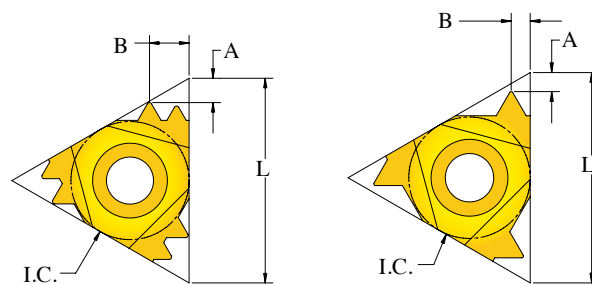
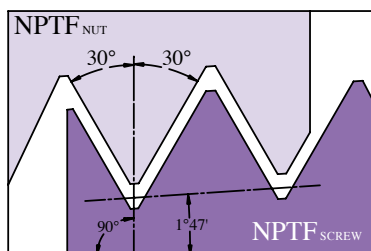

MULTITOOTH

STANDARD

## STANDARD

PITCH TPI	CATALOG NUMBER		DIMENSIONS			
	RIGHT HAND	LEFT HAND	L mm	I.C.	A	B
27	NPTF 27 IR06	NPTF 27 IL06	06	4.00	0.7	0.5
27	NPTF 27 IR08	NPTF 27 IL08	08	5.00	0.7	0.6
18	NPTF 18 IR08	NPTF 18 IL08			0.7	0.7
27	NPTF 27 IR11	NPTF 27 IL11	11	6.35	0.7	0.8
18	NPTF 18 IR11	NPTF 18 IL11			0.8	1.0
14	NPTF 14 IR11	NPTF 14 IL11			0.8	1.0
27	NPTF 27 IR16	NPTF 27 IL16	16	9.525	0.7	0.8
18	NPTF 18 IR16	NPTF 18 IL16			0.8	1.0
14	NPTF 14 IR16	NPTF 14 IL16			0.9	1.2
11.5	NPTF 11.5 IR16	NPTF 11.5 IL16			1.1	1.5
8	NPTF 8 IR16	NPTF 8 IL16			1.3	1.8

## MULTITOOTH

PITCH TPI	TEETH	CATALOG NUMBER RIGHT HAND	ANVIL	DIMENSIONS			
				L mm	I.C.	A	B
11.5	2	NPTF11.5 2M IR22	IS22M	22	12.70	2.4	3.4



## TRAPEZ

### EXTERNAL

DIN 103:1977  
 ISO 2901:1993

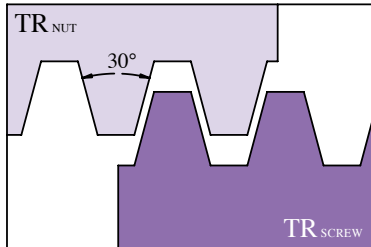

### U TYPE

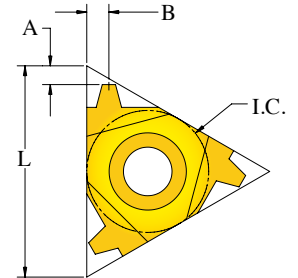
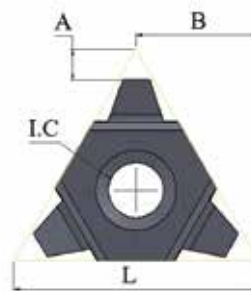

PITCH MM	CATALOG NUMBER		DIMENSIONS			
	RIGHT HAND	LEFT HAND	L mm	I.C.	A	B
1.5	TR 1.5 ER11	TR 1.5 EL11	11	6.35	0.8	0.8
1.5	TR 1.5 ER16	TR 1.5 EL16	16	9.525	1.0	1.1
2.0	TR 2.0 ER16	TR 2.0 EL16			1.1	1.3
3.0	TR 3.0 ER16	TR 3.0 EL16			1.3	1.5
4.0	TR 4.0 ER16	TR 4.0 EL16			1.4	1.6
4.0	TR 4.0 ER22	TR 4.0 EL22	22	12.70	1.7	1.9
5.0	TR 5.0 ER22	TR 5.0 EL22			2.1	2.4
6.0	TR 6.0 ER22	TR 6.0 EL22			2.3	2.6
6.0	TR 6.0 ER/L22 U		27	15.875	2.0	11.0
6.0	TR 6.0 ER27	TR 6.0 EL27			2.2	2.6
7.0	TR 7.0 ER/L22 U		22	12.70	2.3	11.0
7.0	TR 7.0 ER27	TR 7.0 EL27	27	15.875	2.1	2.5
8.0	TR 8.0 ER/L27 U				2.5	13.7
9.0	TR 9.0 ER/L27 U				3.0	13.7
10.0*	TR 10.0 ER/L27 U*				3.2	13.7
12.0	TR 12.0 ER/L33 U		33	19.05	3.9	16.9

\*ONE CUTTING EDGE

### SEMI FULL PROFILE

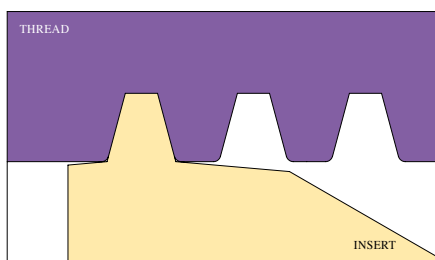

Semi full profile inserts style completes the thread form and breaks the corners of outside thread diameter, used for Trapezoidal threading inserts.

## TRAPEZ INTERNAL

DIN 103:1977

ISO 2901:1993

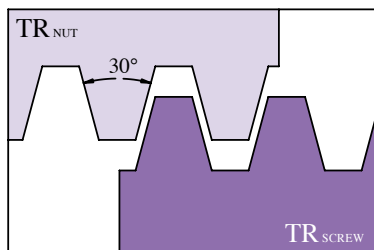

### U TYPE

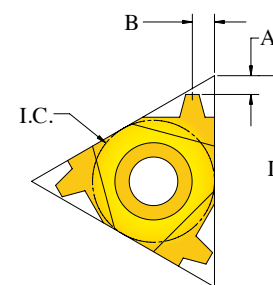
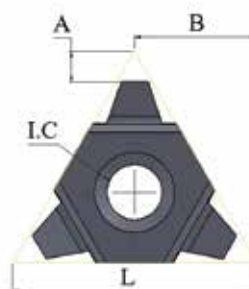

PITCH MM	CATALOG NUMBER		DIMENSIONS			
	RIGHT HAND	LEFT HAND	L mm	I.C.	A	B
1.5	TR 1.5 IR11	TR 1.5 IL11	11	6.35	0.8	0.8
1.5	TR 1.5 IR16	TR 1.5 IL16	16	9.525	1.0	1.1
2.0	TR 2.0 IR16	TR 2.0 IL16			1.1	1.3
3.0	TR 3.0 IR16	TR 3.0 IL16			1.3	1.5
4.0	TR 4.0 IR16	TR 4.0 IL16			1.4	1.6
4.0	TR 4.0 IR22	TR 4.0 IL22	22	12.70	1.7	1.9
5.0	TR 5.0 IR22	TR 5.0 IL22			2.1	2.4
6.0	TR 6.0 IR22	TR 6.0 IL22			2.1	2.5
6.0	TR 6.0 IR/L22 U				2.0	11.0
6.0	TR 6.0 IR27	TR 6.0 IL27	27	15.875	2.2	2.6
7.0	TR 7.0 IR/L22 U		22	12.70	2.3	11.0
7.0	TR 7.0 IR27	TR 7.0 IL27	27	15.875	2.1	2.5
8.0	TR 8.0 IR/L27 U				2.5	13.7
9.0	TR 9.0 IR/L27 U				3.0	13.7
10.0*	TR 10.0 IR/L27 U*				3.2	13.7
12.0	TR 12.0 IR/L33 U		33	19.05	3.9	16.9

**\*ONE CUTTING EDGE**

### SEMI FULL PROFILE

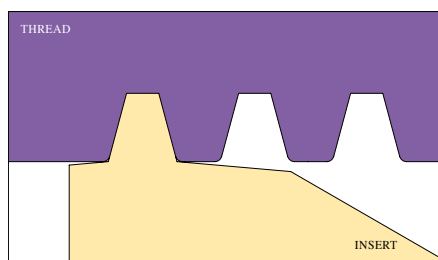

Semi full profile inserts style completes the thread form and breaks the corners of outside thread diameter, used for Trapezoidal threading inserts.

## ACME EXTERNAL

ANSI/ASME 1.5-1988

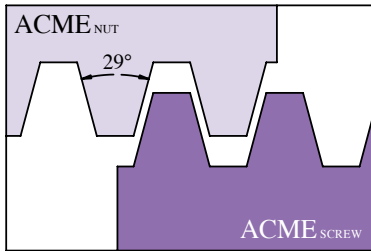

### U TYPE

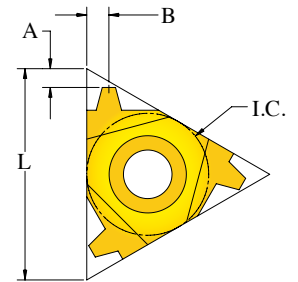
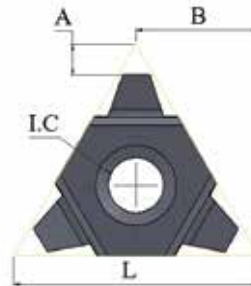

PITCH  TPI	CATALOG NUMBER		DIMENSIONS			
	RIGHT HAND	LEFT HAND	L mm	I.C.	A	B
16	ACME 16 ER11	ACME 16 EL11	11	6.35	1.0	1.1
16	ACME 16 ER16	ACME 16 EL16	16	9.525	1.0	1.1
14	ACME 14 ER16	ACME 14 EL16			1.0	1.2
12	ACME 12 ER16	ACME 12 EL16			1.1	1.2
10	ACME 10 ER16	ACME 10 EL16			1.3	1.4
8	ACME 8 ER16	ACME 8 EL16			1.4	1.5
6	ACME 6 ER22	ACME 6 EL22	22	12.70	1.8	2.1
5	ACME 5 ER22	ACME 5 EL22			2.0	2.3
4	ACME 4 ER22	ACME 4 EL22			2.1	2.2
4	ACME 4 ER/L 22 U				2.3	11.0
4	ACME 4 ER27	ACME 4 EL27	27	15.875	2.4	2.6
3	ACME 3 ER/L 27 U					
2	ACME 2 ER/L 33 U		33	19.05	4.3	16.9

## ACME INTERNAL

ANSI/ASME 1.5-1988

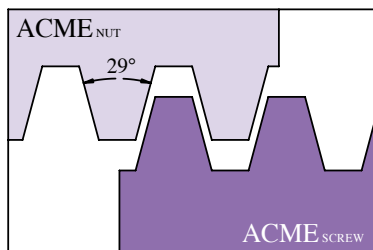

### U TYPE

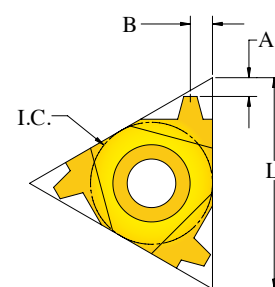
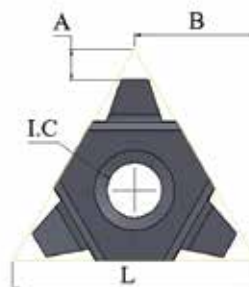

PITCH  TPI	CATALOG NUMBER		DIMENSIONS			
	RIGHT HAND	LEFT HAND	L mm	I.C.	A	B
16	ACME 16 IR11	ACME 16 IL11	11	6.35	1.0	1.1
16	ACME 16 IR16	ACME 16 IL16	16	9.525	1.0	1.1
14	ACME 14 IR16	ACME 14 IL16			1.0	1.2
12	ACME 12 IR16	ACME 12 IL16			1.1	1.2
10	ACME 10 IR16	ACME 10 IL16			1.3	1.4
8	ACME 8 IR16	ACME 8 IL16			1.4	1.5
6	ACME 6 IR16	ACME 6 IL16			1.4	1.5
6	ACME 6 IR22	ACME 6 IL22			22	12.70
5	ACME 5 IR22	ACME 5 IL22	2.0	2.3		
4	ACME 4 IR22	ACME 4 IL22	2.1	2.4		
4	ACME 4 IR/L 22 U		2.3	11.0		
4	ACME 4 IR27	ACME 4 IL27	27	15.875	2.4	2.6
3	ACME 3 IR/L 27 U				2.8	13.7
2	ACME 2 IR/L 33 U		33	19.05	4.3	16.9

## STUB ACME EXTERNAL

ASME/ANSI B 1.8-1988

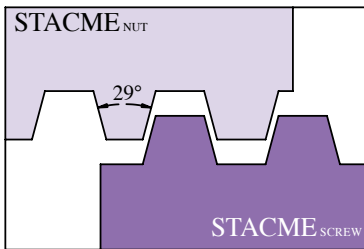

### U TYPE

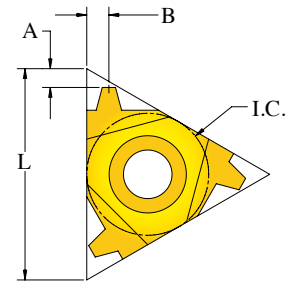
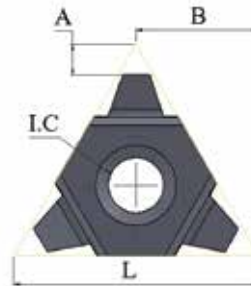

PITCH  TPI	CATALOG NUMBER		DIMENSIONS			
	RIGHT HAND	LEFT HAND	L mm	I.C.	A	B
16	STACME 16 ER11	STACME 16 EL11	11	6.35	1.0	1.1
16	STACME 16 ER16	STACME 16 EL16	16	9.525	1.0	1.1
14	STACME 14 ER16	STACME 14 EL16			1.0	1.2
12	STACME 12 ER16	STACME 12 EL16			1.1	1.2
10	STACME 10 ER16	STACME 10 EL16			1.2	1.4
8	STACME 8 ER16	STACME 8 EL16			1.4	1.5
6	STACME 6 ER16	STACME 6 EL16			1.7	1.8
6	STACME 6 ER22	STACME 6 EL22	22	12.70	1.8	2.1
5	STACME 5 ER22	STACME 5 EL22			2.1	2.3
4	STACME 4 ER22	STACME 4 EL22			2.3	2.3
4	STACME 4 ER/L 22 U				2.5	11.0
4	STACME 4 ER27	STACME 4 EL27	27	15.875	2.4	2.5
3	STACME 3 ER/L 22 U		22	12.70	3.3	11.0
3	STACME 3 ER27	STACME 3 EL27	27	15.875	2.7	2.8
2	STACME 2 ER/L 33 U		33	19.05	5.0	16.9

## STUB ACME INTERNAL

ASME/ANSI B 1.8-1988

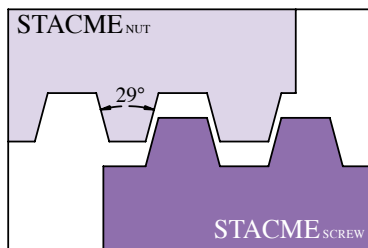

### U TYPE

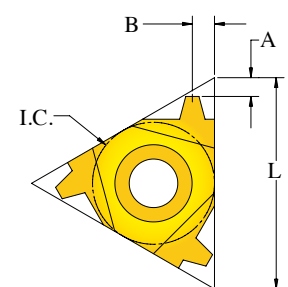
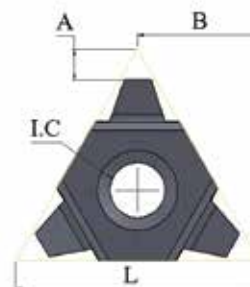

PITCH  TPI	CATALOG NUMBER		DIMENSIONS			
	RIGHT HAND	LEFT HAND	L mm	I.C.	A	B
16	STACME 16 IR11	STACME 16 IL11	11	6.35	1.0	1.1
16	STACME 16 IR16	STACME 16 IL16	16	9.525	1.0	1.1
14	STACME 14 IR16	STACME 14 IL16			1.0	1.2
12	STACME 12 IR16	STACME 12 IL16			1.1	1.2
10	STACME 10 IR16	STACME 10 IL16			1.2	1.4
8	STACME 8 IR16	STACME 8 IL16			1.4	1.5
6	STACME 6 IR16	STACME 6 IL16			1.7	1.8
6	STACME 6 IR22	STACME 6 IL22	22	12.70	1.8	2.1
5	STACME 5 IR22	STACME 5 IL22			2.1	2.3
4	STACME 4 IR22	STACME 4 IL22			2.3	2.3
4	STACME 4 IR/L22 U				2.3	11.0
4	STACME 4 IR27	STACME 4 IL27	27	15.875	2.4	2.5
3	STACME 3 IR/L22 U		22	12.70	3.3	11.0
3	STACME 3 IR27	STACME 3 IL27	27	15.875	2.7	2.8
2	STACME 2 IR/L33 U		33	19.05	5.0	16.9

## AMERICAN BUTTRESS EXTERNAL

ANSI B 1.9-1973

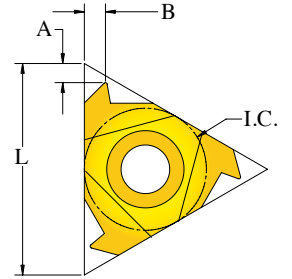
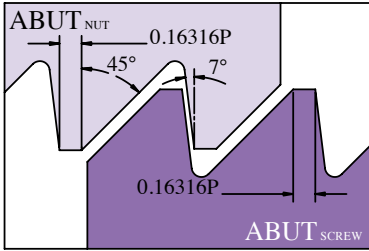

PITCH  TPI	CATALOG NUMBER		DIMENSIONS			
	RIGHT HAND	LEFT HAND	L mm	I.C.	A	B
20	ABUT 20 ER11	ABUT 20 EL11	11	6.35	1.0	1.4
16	ABUT 16 ER11	ABUT 16 EL11			1.1	1.6
20	ABUT 20 ER16	ABUT 20 EL16	16	9.525	1.0	1.4
16	ABUT 16 ER16	ABUT 16 EL16			1.0	1.5
12	ABUT 12 ER16	ABUT 12 EL16			1.4	2.0
10	ABUT 10 ER16	ABUT 10 EL16			1.5	2.3
8	ABUT 8 ER22	ABUT 8 EL22	22	12.70	2.0	3.2
6	ABUT 6 ER22	ABUT 6 EL22			2.1	3.4

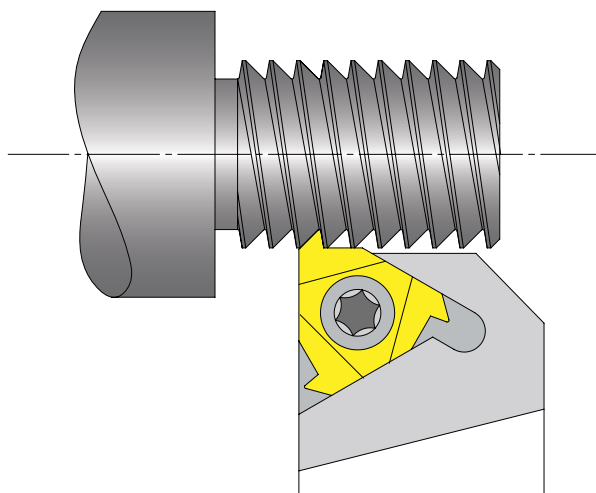

STANDARD LEADING ANGLE: 45°

## AMERICAN BUTTRESS INTERNAL

ANSI B 1.9-1973

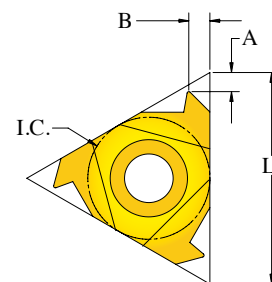
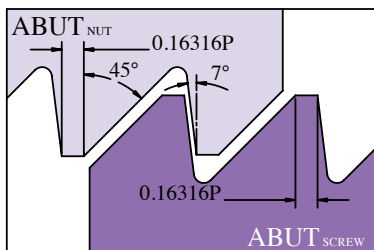

PITCH TPI	CATALOG NUMBER		DIMENSIONS			
	RIGHT HAND	LEFT HAND	L mm	I.C.	A	B
20	ABUT 20 IR11	ABUT 20 IL11	11	6.35	1.0	1.4
16	ABUT 16 IR11	ABUT 16 IL11			1.1	1.6
20	ABUT 20 IR16	ABUT 20 IL16	16	9.525	1.0	1.4
16	ABUT 16 IR16	ABUT 16 IL16			1.0	1.5
12	ABUT 12 IR16	ABUT 12 IL16			1.4	2.0
10	ABUT 10 IR16	ABUT 10 IL16			1.5	2.3
8	ABUT 8 IR22	ABUT 8 IL22	22	12.70	2.0	3.2
6	ABUT 6 IR22	ABUT 6 IL22			2.1	3.4

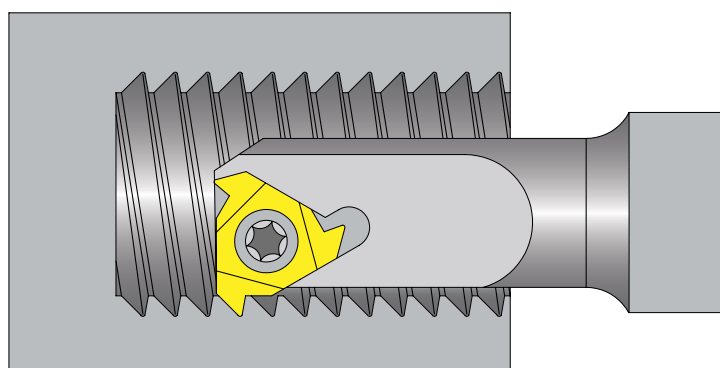

STANDARD LEADING ANGLE: 45°



## UNJ EXTERNAL

MIL-S-8879A

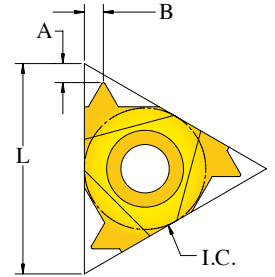
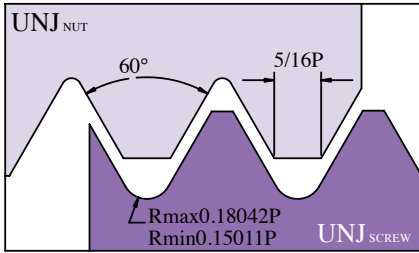

PITCH  TPI	CATALOG NUMBER		DIMENSIONS			
	RIGHT HAND	LEFT HAND	L mm	I.C.	A	B
32	UNJ 32 ER11	UNJ 32 EL11	11	6.35	0.6	0.6
28	UNJ 28 ER11	UNJ 28 EL11			0.6	0.6
24	UNJ 24 ER11	UNJ 24 EL11			0.7	0.8
20	UNJ 20 ER11	UNJ 20 EL11			0.8	0.9
18	UNJ 18 ER11	UNJ 18 EL11			0.8	1.0
16	UNJ 16 ER11	UNJ 16 EL11			0.8	1.0
14	UNJ 14 ER11	UNJ 14 EL11			0.9	1.0
32	UNJ 32 ER16	UNJ 32 EL16	16	9.525	0.6	0.6
28	UNJ 28 ER16	UNJ 28 EL16			0.6	0.6
24	UNJ 24 ER16	UNJ 24 EL16			0.7	0.8
20	UNJ 20 ER16	UNJ 20 EL16			0.8	0.9
18	UNJ 18 ER16	UNJ 18 EL16			0.8	1.0
16	UNJ 16 ER16	UNJ 16 EL16			0.8	1.0
14	UNJ 14 ER16	UNJ 14 EL16			1.0	1.2
13	UNJ 13 ER16	UNJ 13 EL16			1.0	1.3
12	UNJ 12 ER16	UNJ 12 EL16			1.1	1.4
11	UNJ 11 ER16	UNJ 11 EL16			1.1	1.5
10	UNJ 10 ER16	UNJ 10 EL16			1.1	1.5
9	UNJ 9 ER16	UNJ 9 EL16	1.2	1.6		
8	UNJ 8 ER16	UNJ 8 EL16	1.2	1.6		

## UNJ INTERNAL

MIL-S-8879A

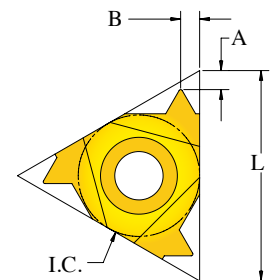
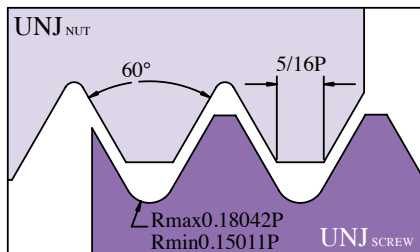

PITCH  TPI	CATALOG NUMBER		DIMENSIONS			
	RIGHT HAND	LEFT HAND	L mm	I.C.	A	B
32	UNJ 32 IR11	UNJ 32 IL11	11	6.35	0.6	0.6
28	UNJ 28 IR11	UNJ 28 IL11			0.6	0.6
24	UNJ 24 IR11	UNJ 24 IL11			0.7	0.8
20	UNJ 20 IR11	UNJ 20 IL11			0.8	0.9
18	UNJ 18 IR11	UNJ 18 IL11			0.8	1.0
16	UNJ 16 IR11	UNJ 16 IL11			0.8	1.0
14	UNJ 14 IR11	UNJ 14 IL11			0.9	1.0
32	UNJ 32 IR16	UNJ 32 IL16	16	9.525	0.6	0.6
28	UNJ 28 IR16	UNJ 28 IL16			0.6	0.6
24	UNJ 24 IR16	UNJ 24 IL16			0.7	0.8
20	UNJ 20 IR16	UNJ 20 IL16			0.8	0.9
18	UNJ 18 IR16	UNJ 18 IL16			0.8	1.0
16	UNJ 16 IR16	UNJ 16 IL16			0.8	1.0
14	UNJ 14 IR16	UNJ 14 IL16			1.0	1.2
12	UNJ 12 IR16	UNJ 12 IL16			1.1	1.4
11	UNJ 11 IR16	UNJ 11 IL16			1.1	1.5
10	UNJ 10 IR16	UNJ 10 IL16			1.1	1.5
9	UNJ 9 IR16	UNJ 9 IL16			1.2	1.6
8	UNJ 8 IR16	UNJ 8 IL16	1.2	1.6		

## ROUND (DIN 405)

DIN 405 : 1997

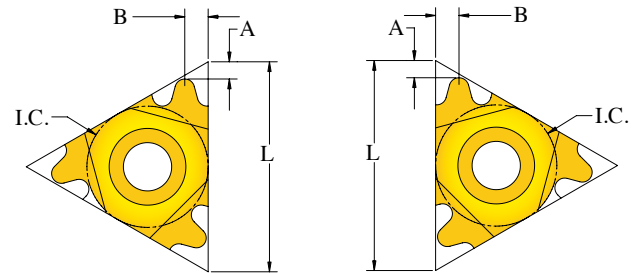
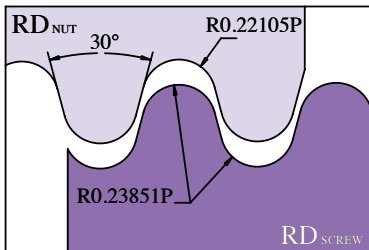

INTERNAL

EXTERNAL

### EXTERNAL

PITCH TPI	CATALOG NUMBER		DIMENSIONS			
	RIGHT HAND	LEFT HAND	L mm	I.C.	A	B
10	RD 10 ER16	RD 10 EL16	16	9.525	1.1	1.2
8	RD 8 ER16	RD 8 EL16			1.4	1.4
6	RD 6 ER16	RD 6 EL16			1.4	1.5
6	RD 6 ER22	RD 6 EL22	22	12.70	1.5	1.7
4	RD 4 ER22	RD 4 EL22			2.2	2.3
4	RD 4 ER27	RD 4 EL27	27	15.875	2.3	2.3

### INTERNAL

PITCH TPI	CATALOG NUMBER		DIMENSIONS			
	RIGHT HAND	LEFT HAND	L mm	I.C.	A	B
10	RD 10 IR16	RD 10 IL16	16	9.525	1.1	1.2
8	RD 8 IR16	RD 8 IL16			1.4	1.4
6	RD 6 IR16	RD 6 IL16			1.4	1.5
6	RD 6 IR22	RD 6 IL22	22	12.70	1.5	1.7
4	RD 4 IR22	RD 4 IL22			2.2	2.3
4	RD 4 IR27	RD 4 IL27	27	15.875	2.3	2.3

## ROUND (DIN 20400)

DIN 20400 : 1990

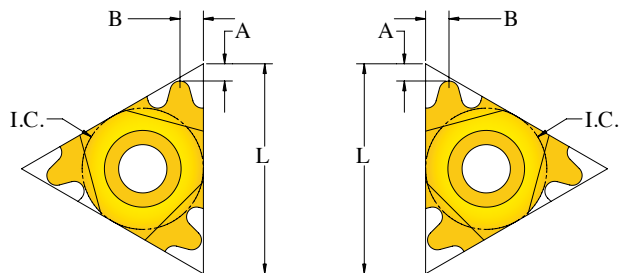
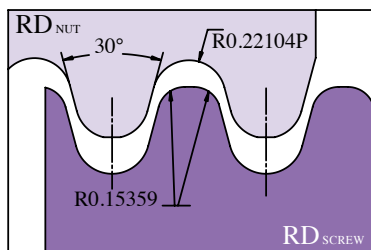

INTERNAL

EXTERNAL

### EXTERNAL

PITCH MM	CATALOG NUMBER		DIMENSIONS			
	RIGHT HAND	LEFT HAND	L mm	I.C.	A	B
3.0	DIN20400 3.0 ER16	DIN20400 3.0 EL16	16	9.525	1.3	1.6
4.0	DIN20400 4.0 ER22	DIN20400 4.0 EL22	22	12.70	1.6	1.5
5.0	DIN20400 5.0 ER22	DIN20400 5.0 EL22			1.6	1.7
6.0	DIN20400 6.0 ER22	DIN20400 6.0 EL22			1.7	2.1

### INTERNAL

PITCH MM	CATALOG NUMBER		DIMENSIONS			
	RIGHT HAND	LEFT HAND	L mm	I.C.	A	B
3.0	DIN20400 3.0 IR16	DIN20400 3.0 IL16	16	9.525	1.3	1.6
4.0	DIN20400 4.0 IR22	DIN20400 4.0 IL22	22	12.70	1.6	1.5
5.0	DIN20400 5.0 IR22	DIN20400 5.0 IL22			1.6	1.7
6.0	DIN20400 6.0 IR22	DIN20400 6.0 IL22			1.7	2.1

## MJ

ISO 5855-1:1989

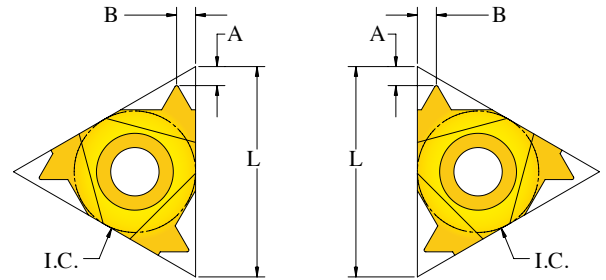
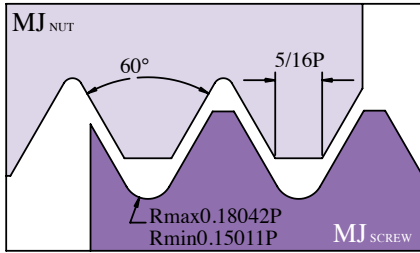

INTERNAL

EXTERNAL

### EXTERNAL

PITCH MM	CATALOG NUMBER RIGHT HAND	DIMENSIONS			
		L mm	I.C.	A	B
1.0	MJ1.0 ER16	16	9.525	0.7	0.8
1.25	MJ1.25 ER16			0.8	0.9
1.5	MJ1.5 ER16			0.8	1.0
2.0	MJ2.0 ER16			1.0	1.3
2.5	MJ2.5 ER16			1.1	1.5
3.0	MJ3.0 ER16			1.1	1.5

### INTERNAL

PITCH MM	CATALOG NUMBER RIGHT HAND	DIMENSIONS			
		L mm	I.C.	A	B
1.0	MJ1.0 IR11	11	6.35	0.7	0.8
1.25	MJ1.25 IR11			0.8	0.9
1.5	MJ1.5 IR11			0.8	1.0
1.0	MJ1.0 IR16	16	9.525	0.7	0.8
1.25	MJ1.25 IR16			0.8	0.9
1.5	MJ1.5 IR16			0.8	1.0
2.0	MJ2.0 IR16			1.0	1.3
2.5	MJ2.5 IR16			0.8	1.5
3.0	MJ3.0 IR16			1.1	1.4

## SAGENGEWINDE

DIN 513 : 1985

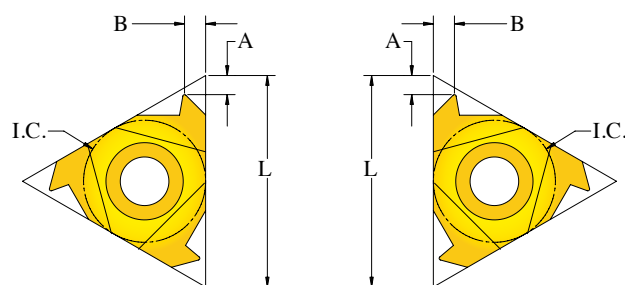
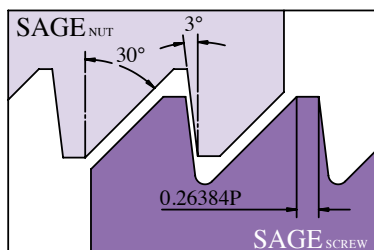

INTERNAL

EXTERNAL

### EXTERNAL

PITCH MM	CATALOG NUMBER		DIMENSIONS			
	RIGHT HAND	LEFT HAND	L mm	I.C.	A	B
2.0	SAGE2.0 ER16	SAGE2.0 EL16	16	9.525	1.3	1.8
3.0	SAGE3.0 ER22	SAGE3.0 EL22	22	12.70	1.8	2.7
4.0	SAGE4.0 ER22	SAGE4.0 EL22			2.1	3.3

### INTERNAL

PITCH MM	CATALOG NUMBER		DIMENSIONS			
	RIGHT HAND	LEFT HAND	L mm	I.C.	A	B
2.0	SAGE2.0 IR16	SAGE2.0 IL16	16	9.525	1.3	1.8
3.0	SAGE3.0 IR22	SAGE3.0 IL22	22	12.70	1.8	2.7
4.0	SAGE4.0 IR22	SAGE4.0 IL22			2.1	3.3

## API EXTERNAL

API SPEC 7 : 2001

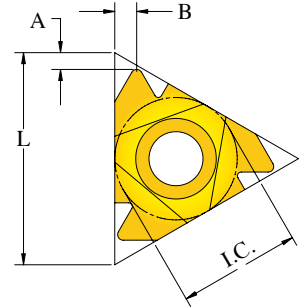
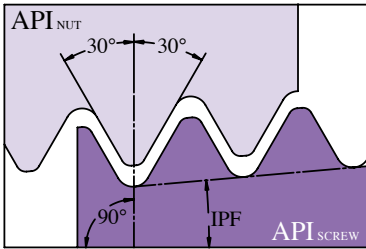

THREAD	PITCH TPI	TAPER IPF	CATALOG NUMBER RIGHT HAND	SIZE	DIMENSIONS			
					L mm	I.C.	A	B
V-0.040	5	3	API5 403 ER22	2 3/8" - 4 1/2" REG	22	12.70	1.8	2.6
V-0.038R	4	2	API4 382 ER22	NC23-NC50			2.0	2.6
V-0.038R	4	3	API4 383 ER22	NC56-NC77			2.0	2.6
V-0.050	4	2	API4 502 ER22	6 5/8" REG			1.9	2.8
V-0.050	4	3	API4 503 ER22	5 1/2" , 7 5/8" , 8 5/8" REG			1.9	2.8
V-0.040	5	3	API5 403 ER27	2 3/8" - 4 1/2" REG	27	15.875	1.9	2.7
V-0.038R	4	2	API4 382 ER27	NC23-NC50			2.2	2.8
V-0.038R	4	3	API4 383 ER27	NC56-NC77			2.2	2.8
V-0.050	4	2	API4 502 ER27	6 5/8" REG			2.2	3.0
V-0.050	4	3	API4 503 ER27	5 1/2" , 7 5/8" , 8 5/8" REG			2.2	3.0

## API INTERNAL

API SPEC 7 : 2001

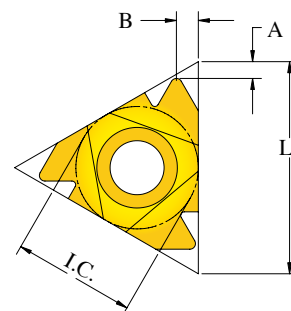
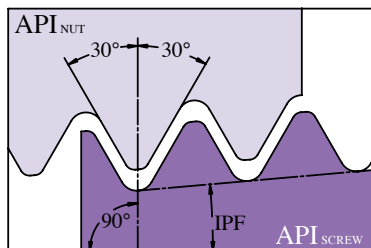

THREAD	PITCH TPI	TAPER IPF	CATALOG NUMBER RIGHT HAND	SIZE	DIMENSIONS			
					L mm	I.C.	A	B
V-0.040	5	3	API5 403 IR22	2 3/8" - 4 1/2" REG	22	12.70	1.8	2.6
V-0.038R	4	2	API4 382 IR22	NC23-NC50			2.0	2.6
V-0.038R	4	3	API4 383 IR22	NC56-NC77			2.0	2.6
V-0.050	4	2	API4 502 IR22	6 5/8" REG			1.9	2.8
V-0.050	4	3	API4 503 IR22	5 1/2" , 7 5/8" , 8 5/8" REG			1.9	2.8
V-0.040	5	3	API5 403 IR27	2 3/8" - 4 1/2" REG	27	15.875	1.9	2.7
V-0.038R	4	2	API4 382 IR27	NC23-NC50			2.2	2.8
V-0.038R	4	3	API4 383 IR27	NC56-NC77			2.2	2.8
V-0.050	4	2	API4 502 IR27	6 5/8" REG			2.2	3.0
V-0.050	4	3	API4 503 IR27	5 1/2" , 7 5/8" , 8 5/8" REG			2.2	3.0



## API ROUND

API SPEC 5B : 2008

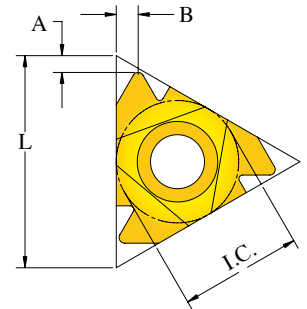
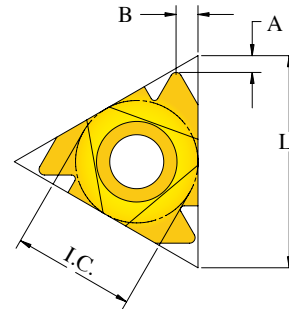
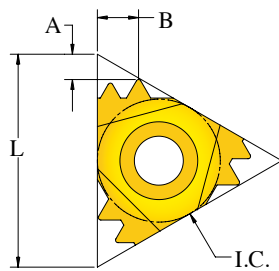
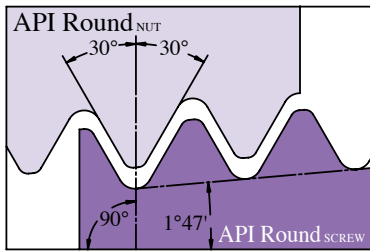

MULTITOOTH

INTERNAL

EXTERNAL

### EXTERNAL

PITCH TPI	TAPER IPF	CATALOG NUMBER RIGHT HAND	DIMENSIONS			
			L mm	I.C.	A	B
10	0.75	APIRD10 ER16	16	9.525	1.4	1.4
8		APIRD8 ER16			1.3	1.5

### INTERNAL

PITCH TPI	TAPER IPF	CATALOG NUMBER RIGHT HAND	DIMENSIONS			
			L mm	I.C.	A	B
10	0.75	APIRD10 IR16	16	9.525	1.4	1.4
8		APIRD8 IR16			1.3	1.5

### MULTITOOTH

PITCH TPI	TEETH	CATALOG NUMBER EXTERNAL		CATALOG NUMBER INTERNAL		DIMENSIONS			
		RIGHT HAND	ANVIL	RIGHT HAND	ANVIL	L mm	I.C.	A	B
10	2	APIRD10 2M ER22	ES22M	APIRD10 2M IR22	IS22M	22	12.70	2.4	3.6
10	3	APIRD10 3M ER27	ES27M	APIRD10 3M IR27	IS27M	27	15.875	3.6	6.3
8	2	APIRD8 2M ER27		APIRD8 2M IR27				2.9	4.6

## BUTTRESS CASING

API SPEC 5B : 2008

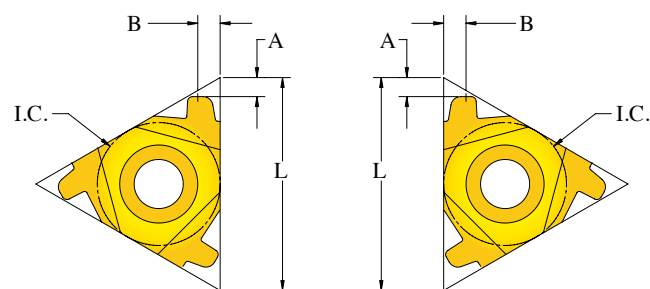
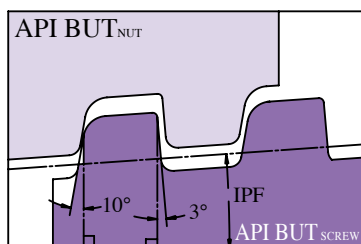

INTERNAL

EXTERNAL

### EXTERNAL

PITCH TPI	TAPER IPF	CATALOG NUMBER RIGHT HAND	SIZE	DIMENSIONS			
				L mm	I.C.	A	B
5	0.75	BUT575 ER22	4 1/2" – 13 3/8"	22	12.70	2.2	2.3
5	1.00	BUT510 ER22	16" - 20"			2.2	2.3

### INTERNAL

PITCH TPI	TAPER IPF	CATALOG NUMBER RIGHT HAND	SIZE	DIMENSIONS			
				L mm	I.C.	A	B
5	0.75	BUT575 IR22	4 1/2" – 13 3/8"	22	12.70	2.2	2.3
5	1.00	BUT510 IR22	16" - 20"			2.2	2.3

## EXTREME LINE CASING

API SPEC 5B : 2008

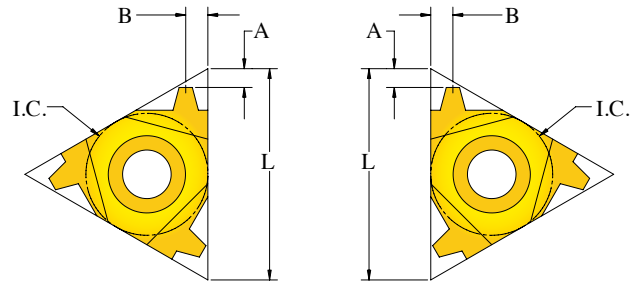
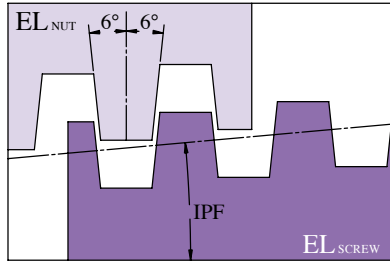

INTERNAL

EXTERNAL

### EXTERNAL

PITCH TPI	TAPER IPF	CATALOG NUMBER RIGHT HAND	SIZE	DIMENSIONS			
				L mm	I.C.	A	B
6	1.5	EL615 ER22	5" - 7 5/8"	22	12.70	2.0	1.9
5	1.25	EL5125 ER22	8 5/8" - 10 3/4"			2.3	2.4

### INTERNAL

PITCH TPI	TAPER IPF	CATALOG NUMBER RIGHT HAND	SIZE	DIMENSIONS			
				L mm	I.C.	A	B
6	1.5	EL615 IR22	5" - 7 5/8"	22	12.70	2.0	1.9
5	1.25	EL5125 IR22	8 5/8" - 10 3/4"			2.3	2.4

## SPECIAL TOOLS

**we are able to manufacture custom tools as per your unique specifications**

In addition to our extensive line of standard threading and grooving tools, EROJET also manufactures special solid carbide, carbide tipped, High Speed Steel, and Stainless Steel cutting tools according to customer specifications. EROJET produces a wide range of special cutting tools for the automotive, electronics, aerospace, communications, and medical industries.



## FLAT GROOVING

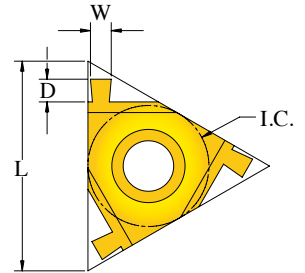
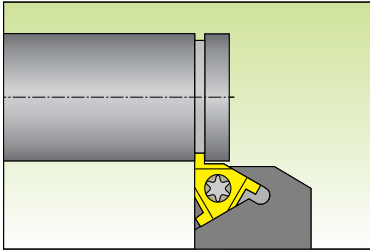

W±0.02	D	CATALOG NUMBER				DIMENSIONS	
		EXTERNAL RIGHT HAND	ANVIL	INTERNAL RIGHT HAND	ANVIL	L mm	I.C.
0.50	1.2			W0.50 IR11		11	6.35
0.79	1.2			W0.79 IR11			
1.00	1.5			W1.00 IR11			
0.50	1.2	W0.50 ER16	ES16-0	W0.50 IR16	IS16-0	16	9.525
0.79	1.2	W0.79 ER16	ES16-0	W0.79 IR16	IS16-0		
1.00	1.5	W1.00 ER16	ES16-0	W1.00 IR16	IS16-0		
1.19	1.8	W1.19 ER16	ES16-0	W1.19 IR16	IS16-0		
1.39	1.9	W1.39 ER16	ES16-0	W1.39 IR16	IS16-0		
1.57	2.0	W1.57 ER16	ES16-0	W1.57 IR16	IS16-0		
1.70	2.0	W1.70 ER16	ES16-0	W1.70 IR16	IS16-0		
1.94	2.0	W1.94 ER16	ES16-0	W1.94 IR16	IS16-0		
2.24	2.0	W2.24 ER16	ES16-0	W2.24 IR16	IS16-0		
2.36	2.0	W2.36 ER16	ES16-0	W2.36 IR16	IS16-0		

Recommended feed rate: 0.05-0.10 mm /rev.

Carbide grade available:K420C

## FULL RADIUS GROOVING

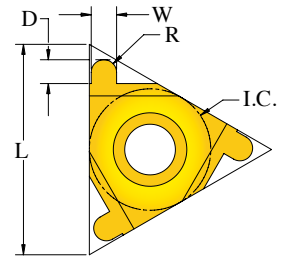
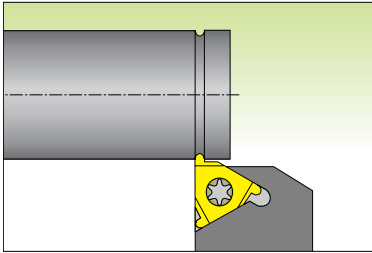

R±0.02	W	D	CATALOG NUMBER				DIMENSIONS	
			EXTERNAL RIGHT HAND	ANVIL	INTERNAL RIGHT HAND	ANVIL	L mm	I.C.
0.50	1.00	1.5	R0.50 ER16	ES16-0	R0.50 IR16	IS16-0	16	9.525
0.75	1.50	2.0	R0.75 ER16	ES16-0	R0.75 IR16	IS16-0		
1.00	2.00	2.0	R1.00 ER16	ES16-0	R1.00 IR16	IS16-0		
1.25	2.50	2.0	R1.25 ER16	ES16-0	R1.25 IR16	IS16-0		

Recommended feed rate: 0.05-0.10 mm /rev.

Carbide grade available:K420C

## TOOLHOLDERS ORDERING CODE

HER	2020	K	16	V- VERTICAL U- U TYPE																
<b>HOLDER TYPE</b>	<b>SHANK</b>	<b>TOOL LENGTH</b>	<b>INSERT SIZE</b>																	
HER - EX. R.H HEL - EX. L.H HIR - IN. R.H HIL - IN. L.H	EXTERNAL TOOLHOLDERS SQUARE SHANK  8 10 12 16 20 25 32  INTERNAL TOOLHOLDERS ROUND SHANK  10 12 16 20 25 32 40	H - 100 K - 125 L - 140 M - 150 P - 170 R - 200 S - 250 T - 300	<table border="1"> <thead> <tr> <th>L</th> <th>I.C.</th> </tr> </thead> <tbody> <tr> <td>06</td> <td>4.00</td> </tr> <tr> <td>08</td> <td>5.00</td> </tr> <tr> <td>11</td> <td>6.35</td> </tr> <tr> <td>16</td> <td>9.525</td> </tr> <tr> <td>22</td> <td>12.70</td> </tr> <tr> <td>27</td> <td>15.875</td> </tr> <tr> <td>33</td> <td>19.05</td> </tr> </tbody> </table>	L	I.C.	06	4.00	08	5.00	11	6.35	16	9.525	22	12.70	27	15.875	33	19.05	
L	I.C.																			
06	4.00																			
08	5.00																			
11	6.35																			
16	9.525																			
22	12.70																			
27	15.875																			
33	19.05																			

## EXTERNAL TOOLHOLDERS

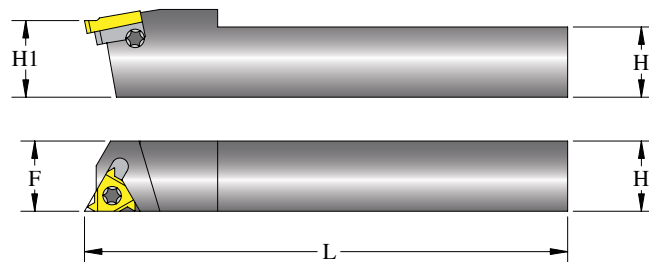
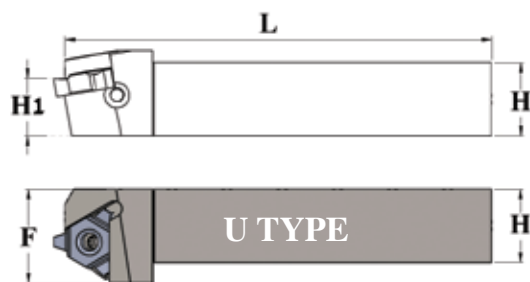

INSERT TYPE	CATALOG NUMBER	H=H1	F	L	SPARE PARTS				
					ANVIL R.H.	ANVIL L.H.	ANVIL SCREW	TORX KEY	INSERT SCREW
ER11	HER0808H11	8.0	10.0	100	-	-	-	KT8	SI11
	HER1010H11	10.0	10.0	100	-	-	-	KT8	SI11
ER16	HER1212H16	12.0	16.0	100	ES16	IS16	SA16	KT10	SI16
	HER1616H16	16.0	16.0	100	ES16	IS16	SA16	KT10	SI16
	HER2020K16	20.0	20.0	125	ES16	IS16	SA16	KT10	SI16
	HER2525M16	25.0	25.0	150	ES16	IS16	SA16	KT10	SI16
	HER3232P16	32.0	32.0	170	ES16	IS16	SA16	KT10	SI16
ER22	HER2525M22	25.0	25.0	150	ES22	IS22	SA22	KT20	SI22
	HER3232P22	32.0	32.0	170	ES22	IS22	SA22	KT20	SI22
ER22U	HER2525M22U	25.0	25.0	150	ES22U	IS22U	SA22	KT20	SI22
	HER3232P22U	32.0	32.0	170	ES22U	IS22U	SA22	KT20	SI22
ER27	HER2525M27	25.0	32.0	150	ES27	IS27	SA27	KT25	SI27
	HER3232P27	32.0	32.0	170	ES27	IS27	SA27	KT25	SI27
ER27U	HER2525M27U	25.0	32.0	150	ES27U	IS27U	SA27	KT25	SI27
	HER3232P27U	32.0	32.0	170	ES27U	IS27U	SA27	KT25	SI27
ER33U	HER2525M33U*	25.0	32.0	150	-	-	-	KT33	SI33
	HER3232P33U*	32.0	32.0	170	-	-	-	KT33	SI33

\*WITHOUT ANVIL

## VERTICAL TOOLHOLDERS

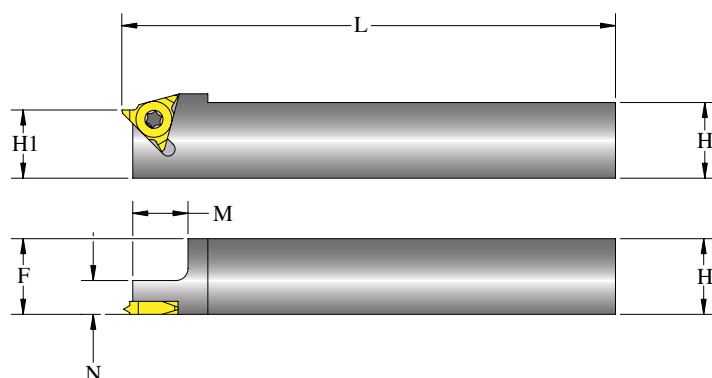

INSERT TYPE	CATALOG NUMBER	N	M	H=H1	F	L	SPARE PARTS	
							TORX KEY	INSERT SCREW
ER16V	HER1616H16V	7.5	15.5	16.0	16.0	100	KT10	SI16V
	HER2020K16V	7.5	15.5	20.0	20.0	125	KT10	SI16V
	HER2525M16V	7.5	15.5	25.0	25.0	150	KT10	SI16V

ALL TOOLHOLDERS ARE MADE WITH 1.5 HELIX ANGLE.  
FOR EX. L.H. INSERTS , CHANGE TO HEL INSTEAD OF HER.



## INTERNAL TOOLHOLDERS

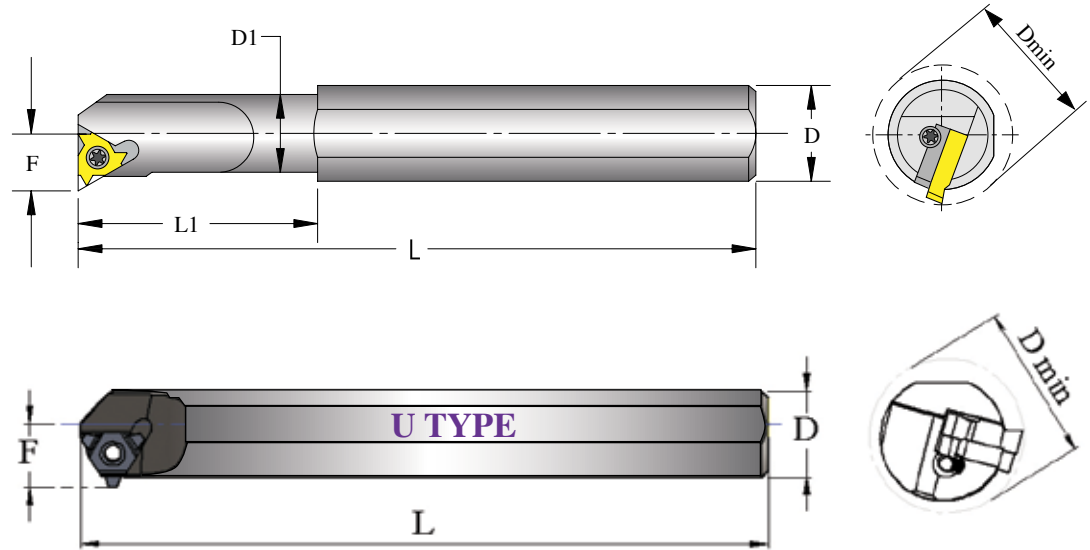

INSERT TYPE	CATALOG NUMBER	D	D1	Dmin	L	L1	F	SPARE PARTS				
								ANVIL R.H.	ANVIL L.H.	ANVIL SCREW	TORX KEY	INSERT SCREW
IR06	HIR0012H06	12.0	5.0	6.1	100	12	4.4	-	-	-	KT6	SI06
IR08	HIR0016K08	16.0	6.5	8.0	125	17	5.4	-	-	-	KT6	SI08
	HIR0016K08M	16.0	7.8	9.2	125	17	5.4	-	-	-	KT6	SI08
IR11	HIR0010H11	10.0	10.0	12.5	100	-	7.3	-	-	-	KT8	SI11
	HIR0010K11	16.0	10.0	12.5	125	25	7.3	-	-	-	KT8	SI11
IR16	HIR0013M16	16.0	13.0	16.5	150	32	10.4	-	-	-	KT10	SI16T
	HIR0016P16	20.0	16.0	19.5	170	40	11.6	-	-	-	KT10	SI16T
	HIR0020P16	20.0	20.0	23.5	170	-	13.6	IS16	ES16	SA16	KT10	SI16
	HIR0025R16	25.0	25.0	28.5	200	-	16.3	IS16	ES16	SA16	KT10	SI16
	HIR0032S16	32.0	32.0	35.5	250	-	19.6	IS16	ES16	SA16	KT10	SI16
	HIR0040T16	40.0	40.0	43.5	300	-	23.6	IS16	ES16	SA16	KT10	SI16
IR22	HIR0020P22	20.0	20.0	25.0	170	-	15.5	-	-	-	KT20	SI22T
	HIR0025R22	25.0	25.0	30.0	200	-	18.3	IS22	ES22	SA22	KT20	SI22
	HIR0032S22	32.0	32.0	37.0	250	-	21.7	IS22	ES22	SA22	KT20	SI22
	HIR0040T22	40.0	40.0	45.0	300	-	25.7	IS22	ES22	SA22	KT20	SI22
IR22U	HIR0032S22U	32.0	32.0	38.0	250	-	24.4	IS22U	ES22U	SA22	KT20	SI22
	HIR0040T22U	40.0	40.0	46.0	300	-	28.1	IS22U	ES22U	SA22	KT20	SI22
IR27	HIR0032S27	32.0	32.0	39.0	250	-	22.8	IS27	ES27	SA27	KT25	SI27
	HIR0040T27	40.0	40.0	47.0	300	-	26.8	IS27	ES27	SA27	KT25	SI27
IR27U	HIR0032S27U	32.0	32.0	40.0	250	-	25.8	IS27U	ES27U	SA27	KT25	SI27
	HIR0040T27U	40.0	40.0	48.0	300	-	29.4	IS27U	ES27U	SA27	KT25	SI27
IR33U	HIR0050P33U*	50.0	50.0	62.0	350	-	37.5	-	-	-	KT33	SI33

ALL TOOLHOLDERS ARE MADE WITH 1.5 HELIX ANGLE.  
 FOR IN. L.H. TOOLHOLDERS, CHANGE TO HIL INSTEAD OF HIR.  
 \*WITHOUT ANVIL

## MACHINING CONDITIONS

ISO	MATERIAL	HARDNESS HB	COATED		UNCOATED
			K420C	K325C	K200
			CUTTING SPEED M/MIN		
<b>P</b>	NON-ALLOY STEEL FREE MACHINING STEEL	130	120-200	110-180	
	LOW CARBON ALLOY STEEL	200	110-180	100-170	
	HIGH CARBON ALLOY STEEL	240	100-170	90-160	
	TOOL STEEL CAST STEEL	270	70-120	60-110	
	HEAT TREATED STEEL	400	50-90	50-90	
<b>M</b>	300 STAINLESS STEEL : ( 303,304,316 )	200	70-140	70-130	
	400 STAINLESS STEEL : (420, 440 )	240	80-120	80-130	
	17-4 PH, 15-5 PH, 13-8MO PH	400	50-110	50-110	
<b>K</b>	GREY CAST IRON	190	70-150	80-150	80-120
	NODULAR CAST IRON	180	100-140	90-130	90-130
	MALLEABLE CAST IRON	240	90-150	90-140	80-130
<b>N</b>	WROUGHT ALUMINUM: ( 2024, 6061, 7075... )	80	100-400	100-400	100-300
	CAST ALUMINUM :	90	150-400	150-400	100-250
	COPPER ALLOYS: BRASS, BRONZE, COPPER SILICON	100	80-180	80-180	60-150
	NON METALIC: Rubber, Polypropylene, Thermoplastics ( PVC ), Thermosetting Plastics ( FIBERGLASS ), Polyamides,		200-500	200-500	200-500
<b>S</b>	TITANIUM :				
	PURE TITANIUM: 99.0Ti		100-150	100-150	70-130
	ALPHA ALLOYS:Ti 5Al2.5Sn		40-60	40-60	30-50
	BETA ALLOYS : Ti 13V11Cr3Al		30-50	30-50	25-40
	ALPHA-BETA ALLOYS : Ti 6Al4V		30-50	30-50	25-40
	COBALT BASE ALLOYS : STELLITE	350	20-40	20-40	20-30
	NIKEL BASE ALLOYS: INCONEL, HASTELLOY, WASPALLOY, KOVAR	300	20-40	20-35	20-40
	HIGH TEMPERATURE ALLOYS: IRON BASED : INCOLOY	270	30-60	30-50	
<b>H</b>	HARDENED STEEL	56 HRc	30-50	25-45	
	HARDENED CAST IRON	50 HRc	25-35	25-40	

## CARBIDE GRADES

**K420C** : AN ADVANCED PVD TiAlN COATED GRADE OVER A TOUGH WEAR-RESISTANT SUBMICRON SUBSTRATE FOR GENERAL PURPOSE MACHINING OF STEEL, STAINLESS STEEL, SUPERALLOYS.

**K325C** : SPECIAL MULTILAYER PVD COATING WITH A TOUGH, VERY FINE GRAIN SUBSTRATE, FOR MACHINING MOST STEEL, STAINLESS STEELS, CAST IRON, NON-FERROUS MATERIALS AND SUPER ALLOYS.

**K200** : UNCOATED GRADE , FOR MACHINING CAST IRON, NON-FERROUS MATERIALS ALUMINUM AND SUPER ALLOYS.

GRADES		P				M				K				N				S				H			
		P10	P20	P30	P40	M10	M20	M30	M40	K10	K20	K30	K40	N10	N20	N30	N40	S10	S20	S30	S40	H10	H20	H30	H40
COATED	<b>K420C</b>	○				○				○				○				○							
	<b>K325C</b>	○				○				○				○				○							
UNCOATED	<b>K200</b>									○				○				○							

## HELIX ANGLE ANVILS SELECTION

L	HOLDER TYPE	THREAD HELIX ANGLE							
		4.5	3.5	2.5	1.5	0.5	0	-0.5	-1.5
16	ER/IL	ES16+4.5	ES16+3.5	ES16+2.5	ES16	ES16+0.5	ES16-0	ES16-0.5	ES16-1.5
	IR/EL	IS16+4.5	IS16+3.5	IS16+2.5	IS16	IS16+0.5	IS16-0	IS16-0.5	IS16-1.5
22	ER/IL	ES22+4.5	ES22+3.5	ES22+2.5	ES22	ES22+0.5	ES22-0	ES22-0.5	ES22-1.5
	IR/EL	IS22+4.5	IS22+3.5	IS22+2.5	IS22	IS22+0.5	IS22-0	IS22-0.5	IS22-1.5
27	ER/IL	ES27+4.5	ES27+3.5	ES27+2.5	ES27	ES27+0.5	ES27-0	ES27-0.5	ES27-1.5
	IR/EL	IS27+4.5	IS27+3.5	IS27+2.5	IS27	IS27+0.5	IS27-0	IS27-0.5	IS27-1.5

## WORK METHODS

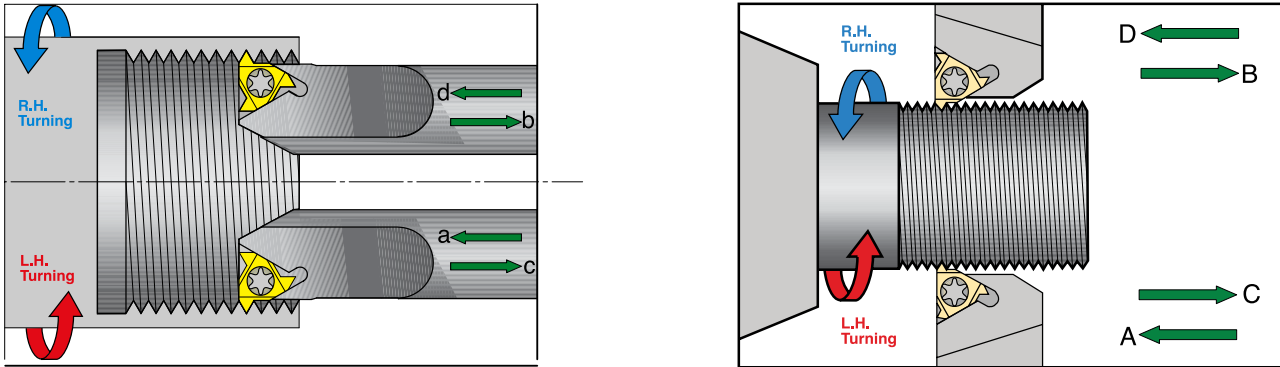

METHOD	THREAD TYPE	TURNING	INSERT & TOOLHOLDER TYPE
A, a	R.H.	R.H.	R.H.
B, b	R.H.	L.H.	L.H.
C, c	L.H.	R.H.	R.H.
D, d	L.H.	L.H.	L.H.

## THREAD HELIX ANGLE

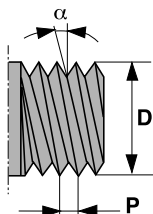
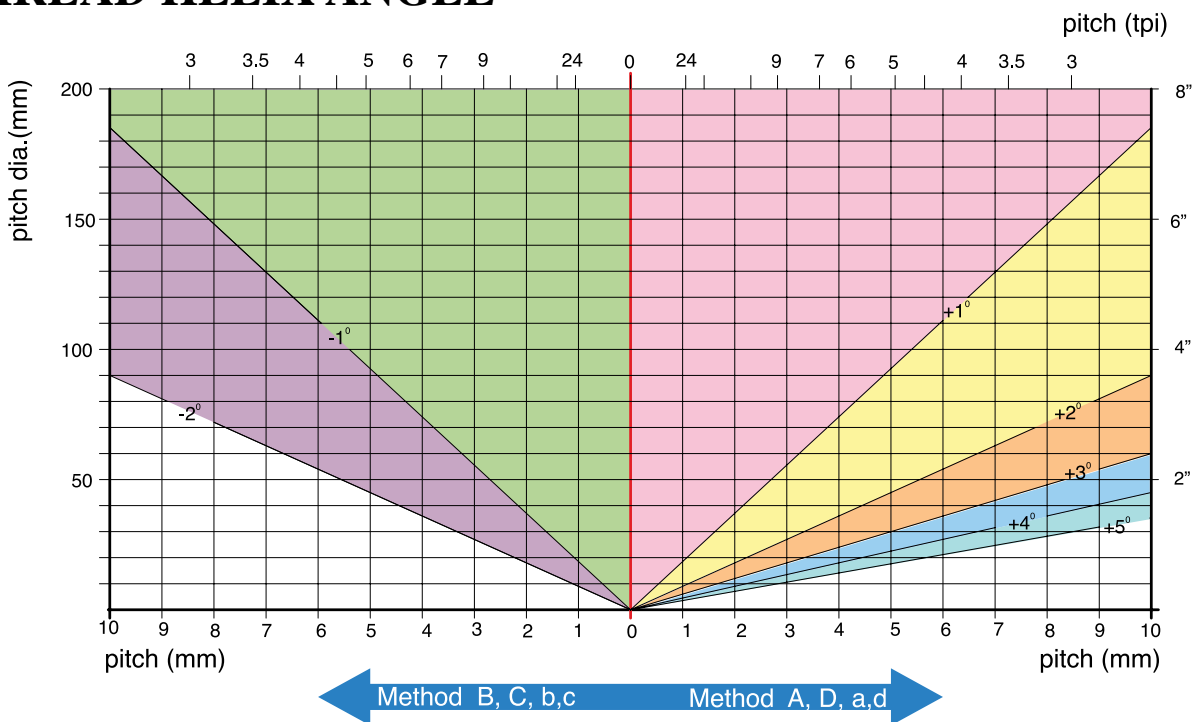

$$\text{tg } \alpha = \frac{P}{\pi D}$$

All Standard Toolholders made with  $1 \frac{1}{2}^\circ$  helix angle. If the helix angle  $\alpha < 1^\circ$  or  $\alpha > 2^\circ$  then the anvil must change. In case of method B, C, b, c. The anvil must change to negative anvil.

## FLANK CLEARANCE ANGLE- $\gamma$

$$\gamma = \text{tg}^{-1} [\text{tg} \alpha \times \text{tg} \delta]$$

$\alpha = 10^\circ$  for external

$\alpha = 15^\circ$  for internal

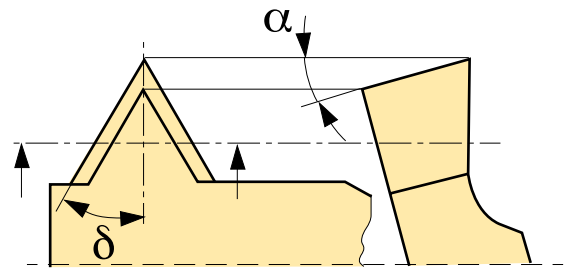
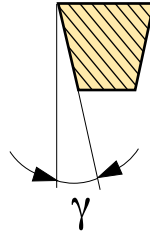

## TROUBLESHOOTING

PROBLEM	CAUSE	SOLUTION
<b>PLASTIC DEFORMATION</b>	WRONG CARBIDE GRADE INSUFFICIENT COOLANT CUTTING SPEED TOO HIGH CUTTING RESISTANCE HIGH	CHANGE GRADE CHECK COOLANT FLOW DECREASE CUTTING SPEED INCREASE THE NUMBER OF PASSES
<b>FRACTURE AND CHIPPING</b>	UNSTABLE CONDITIONS CUTTING SPEED TOO HIGH DEPTH OF CUT LARGE POOR CHIP CONTROL WRONG CARBIDE GRADE INCORRECT CENTER HIGH WRONG ANVIL	CHECK TOOL AND WORKPIECE CLAMPING AND STABILITY DECREASE CUTTING SPEED INCREASE THE NUMBER OF PASSES CHANGE TO FLANK FEED CHANGE GRADE CHECK CENTER HIGH CHECK HELIX ANGLE
<b>BUILT UP EDGE</b>	INCORRECT CUTTING SPEED WRONG CARBIDE GRADE INSUFFICIENT COOLANT	INCREASE CUTTING SPEED CHANGE GRADE INCREASE COOLANT FLOW
<b>VIBRATIONS</b>	CUTTING SPEED TOO HIGH INCORRECT TOOL AND WORKPIECE INSTALLATION LARGE DEPTH OF CUT	CHANGE CUTTING SPEED CHECK CENTER HIGH AND CLAMPING INCREASE NUMBER OF PASSES
<b>ASYMMETRIC WEAR OF THREAD FLANKS</b>	INCORRECT ANVIL	CALCULATE HELIX ANGLE AND SELECT AN APPROPRIATE ANVIL

## ISO METRIC EXTERNAL THREAD RECOMMENDED NO OF PASSES

NO. OF PASSES	PITCH ( MM )															
	6	5.5	5	4.5	4	3.5	3	2.5	2	1.75	1.5	1.25	1	0.75	0.5	0.35
1	0.45	0.43	0.42	0.39	0.34	0.34	0.27	0.26	0.24	0.23	0.23	0.20	0.19	0.17	0.11	0.1
2	0.37	0.36	0.37	0.33	0.30	0.31	0.23	0.22	0.23	0.21	0.21	0.18	0.16	0.15	0.09	0.08
3	0.33	0.31	0.31	0.29	0.25	0.24	0.20	0.20	0.19	0.16	0.18	0.14	0.13	0.11	0.08	0.06
4	0.28	0.27	0.28	0.25	0.21	0.20	0.18	0.17	0.17	0.14	0.16	0.12	0.10	0.06	0.06	
5	0.26	0.25	0.25	0.23	0.19	0.19	0.17	0.16	0.15	0.12	0.11	0.10	0.06			
6	0.24	0.23	0.23	0.20	0.18	0.17	0.16	0.14	0.12	0.10	0.06	0.06				
7	0.23	0.22	0.21	0.19	0.16	0.16	0.15	0.13	0.10	0.08						
8	0.22	0.20	0.20	0.18	0.15	0.15	0.13	0.12	0.06	0.06						
9	0.20	0.19	0.19	0.16	0.15	0.14	0.12	0.10								
10	0.19	0.18	0.18	0.15	0.14	0.12	0.11	0.06								
11	0.18	0.17	0.16	0.14	0.13	0.10	0.09									
12	0.17	0.16	0.14	0.12	0.12	0.06	0.06									
13	0.16	0.15	0.10	0.10	0.10											
14	0.14	0.12	0.06	0.06	0.06											
15	0.13	0.10														
16	0.10	0.06														
17	0.06															
18																
TOTAL	3.71	3.40	3.10	2.79	2.48	2.18	1.87	1.56	1.26	1.10	0.95	0.80	0.64	0.49	0.34	0.24

## ISO METRIC INTERNAL THREAD RECOMMENDED NO OF PASSES

NO. OF PASSES	PITCH ( MM )															
	6	5.5	5	4.5	4	3.5	3	2.5	2	1.75	1.5	1.25	1	0.75	0.5	0.35
1	0.44	0.43	0.42	0.36	0.32	0.32	0.25	0.25	0.23	0.22	0.22	0.19	0.18	0.16	0.10	0.09
2	0.36	0.34	0.37	0.32	0.27	0.29	0.22	0.21	0.21	0.20	0.20	0.16	0.15	0.14	0.09	0.08
3	0.32	0.29	0.28	0.28	0.22	0.23	0.19	0.19	0.18	0.15	0.17	0.13	0.12	0.10	0.07	0.06
4	0.27	0.24	0.26	0.25	0.20	0.19	0.17	0.16	0.16	0.13	0.15	0.11	0.10	0.06	0.06	
5	0.25	0.23	0.24	0.22	0.19	0.18	0.16	0.15	0.14	0.11	0.10	0.10	0.06			
6	0.23	0.22	0.21	0.19	0.18	0.16	0.16	0.13	0.11	0.09	0.06	0.06				
7	0.22	0.21	0.20	0.18	0.16	0.15	0.14	0.12	0.09	0.08						
8	0.21	0.20	0.19	0.17	0.15	0.14	0.12	0.11	0.06	0.06						
9	0.19	0.18	0.18	0.15	0.14	0.13	0.11	0.09								
10	0.17	0.16	0.16	0.14	0.14	0.11	0.10	0.06								
11	0.16	0.16	0.14	0.12	0.12	0.09	0.08									
12	0.15	0.15	0.12	0.10	0.10	0.06	0.06									
13	0.14	0.14	0.09	0.09	0.09											
14	0.13	0.11	0.06	0.06	0.06											
15	0.11	0.09														
16	0.09	0.06														
17	0.06															
18																
TOTAL	3.50	3.21	2.92	2.63	2.34	2.05	1.76	1.47	1.18	1.04	0.90	0.75	0.61	0.46	0.32	0.23

## UN EXTERNAL THREAD RECOMMENDED NO OF PASSES

NO. OF PASSES	PITCH																		
	TPI																		
	4	4.5	5	6	7	8	9	10	11	12	13	14	16	18	20	24	28	32	48
1	0.44	0.43	0.42	0.37	0.33	0.29	0.29	0.26	0.25	0.25	0.24	0.23	0.22	0.21	0.20	0.20	0.18	0.18	0.13
2	0.38	0.35	0.37	0.32	0.28	0.22	0.24	0.22	0.22	0.23	0.22	0.20	0.20	0.19	0.16	0.17	0.15	0.16	0.09
3	0.33	0.30	0.32	0.27	0.23	0.20	0.23	0.20	0.19	0.20	0.18	0.18	0.18	0.17	0.15	0.14	0.11	0.12	0.07
4	0.29	0.28	0.27	0.25	0.22	0.18	0.22	0.17	0.17	0.18	0.16	0.14	0.14	0.16	0.13	0.11	0.09	0.06	0.06
5	0.27	0.26	0.26	0.24	0.21	0.17	0.18	0.16	0.16	0.16	0.14	0.12	0.11	0.11	0.11	0.06	0.06		
6	0.26	0.23	0.24	0.18	0.19	0.16	0.16	0.15	0.15	0.14	0.13	0.11	0.09	0.06	0.06				
7	0.24	0.22	0.22	0.17	0.18	0.16	0.15	0.14	0.13	0.11	0.10	0.10	0.06						
8	0.23	0.21	0.20	0.16	0.15	0.15	0.12	0.12	0.12	0.06	0.06	0.06							
9	0.21	0.20	0.19	0.15	0.14	0.14	0.11	0.11	0.06										
10	0.20	0.19	0.18	0.13	0.14	0.14	0.06	0.06											
11	0.19	0.18	0.17	0.12	0.12	0.11													
12	0.18	0.17	0.14	0.10	0.06	0.06													
13	0.18	0.15	0.11	0.11															
14	0.17	0.14	0.06	0.06															
15	0.16	0.12																	
16	0.13	0.06																	
17	0.06																		
<b>TOTAL</b>	<b>3.92</b>	<b>3.49</b>	<b>3.15</b>	<b>2.63</b>	<b>2.25</b>	<b>1.98</b>	<b>1.76</b>	<b>1.59</b>	<b>1.45</b>	<b>1.33</b>	<b>1.23</b>	<b>1.14</b>	<b>1.00</b>	<b>0.90</b>	<b>0.81</b>	<b>0.68</b>	<b>0.59</b>	<b>0.52</b>	<b>0.35</b>

## UN INTERNAL THREAD RECOMMENDED NO OF PASSES

NO. OF PASSES	PITCH																		
	TPI																		
	4	4.5	5	6	7	8	9	10	11	12	13	14	16	18	20	24	28	32	48
1	0.43	0.43	0.42	0.34	0.31	0.29	0.29	0.25	0.24	0.24	0.23	0.22	0.21	0.20	0.19	0.19	0.17	0.17	0.12
2	0.34	0.35	0.37	0.28	0.27	0.22	0.23	0.21	0.20	0.21	0.21	0.20	0.19	0.18	0.16	0.16	0.14	0.15	0.09
3	0.32	0.29	0.28	0.26	0.22	0.19	0.20	0.19	0.18	0.19	0.17	0.17	0.17	0.16	0.14	0.13	0.10	0.11	0.07
4	0.28	0.24	0.26	0.22	0.20	0.17	0.20	0.16	0.16	0.17	0.15	0.13	0.13	0.15	0.11	0.10	0.08	0.06	0.06
5	0.26	0.23	0.24	0.21	0.19	0.16	0.16	0.15	0.15	0.15	0.13	0.11	0.10	0.09	0.10	0.06	0.06		
6	0.25	0.22	0.21	0.18	0.18	0.16	0.15	0.13	0.14	0.13	0.12	0.10	0.09	0.06	0.06				
7	0.23	0.21	0.20	0.17	0.16	0.14	0.14	0.12	0.12	0.10	0.09	0.09	0.06						
8	0.21	0.20	0.19	0.16	0.15	0.14	0.13	0.12	0.10	0.06	0.06	0.06							
9	0.20	0.19	0.18	0.15	0.14	0.13	0.11	0.11	0.06										
10	0.19	0.18	0.16	0.13	0.14	0.12	0.06	0.06											
11	0.18	0.17	0.16	0.12	0.10	0.08													
12	0.17	0.16	0.13	0.10	0.06	0.06													
13	0.16	0.14	0.10	0.09															
14	0.16	0.12	0.06	0.06															
15	0.14	0.10																	
16	0.12	0.06																	
17	0.06																		
<b>TOTAL</b>	<b>3.70</b>	<b>3.29</b>	<b>2.96</b>	<b>2.47</b>	<b>2.12</b>	<b>1.86</b>	<b>1.67</b>	<b>1.50</b>	<b>1.35</b>	<b>1.25</b>	<b>1.16</b>	<b>1.08</b>	<b>0.95</b>	<b>0.84</b>	<b>0.76</b>	<b>0.64</b>	<b>0.55</b>	<b>0.49</b>	<b>0.34</b>

**W ( BSP, BSPT )**  
**EXTERNAL THREAD**  
**RECOMMENDED NO OF PASSES**

NO. OF PASSES	PITCH																		
	TPI																		
	4	4.5	5	6	7	8	9	10	11	12	14	16	18	19	20	24	28	32	48
1	0.45	0.44	0.43	0.38	0.34	0.30	0.28	0.27	0.26	0.26	0.24	0.22	0.24	0.22	0.21	0.20	0.18	0.19	0.16
2	0.40	0.36	0.38	0.33	0.29	0.24	0.25	0.23	0.23	0.23	0.21	0.18	0.21	0.19	0.19	0.18	0.15	0.16	0.14
3	0.35	0.31	0.33	0.28	0.24	0.21	0.22	0.21	0.20	0.21	0.17	0.15	0.16	0.17	0.15	0.16	0.12	0.13	0.06
4	0.31	0.29	0.28	0.27	0.23	0.19	0.21	0.18	0.18	0.19	0.15	0.13	0.15	0.14	0.13	0.11	0.10	0.06	
5	0.28	0.27	0.27	0.25	0.22	0.18	0.20	0.17	0.17	0.17	0.14	0.12	0.11	0.11	0.10	0.06	0.06		
6	0.27	0.24	0.25	0.19	0.20	0.17	0.17	0.16	0.16	0.15	0.12	0.10	0.06	0.06	0.06				
7	0.25	0.23	0.23	0.18	0.19	0.17	0.17	0.14	0.13	0.12	0.10	0.09							
8	0.24	0.22	0.21	0.17	0.16	0.16	0.15	0.13	0.12	0.06	0.06	0.06							
9	0.22	0.21	0.20	0.16	0.15	0.14	0.13	0.11	0.06										
10	0.21	0.20	0.19	0.14	0.15	0.13	0.06	0.06											
11	0.20	0.19	0.18	0.12	0.12	0.11													
12	0.19	0.18	0.15	0.10	0.06	0.06													
13	0.18	0.16	0.12	0.11															
14	0.18	0.15	0.06	0.06															
15	0.17	0.13																	
16	0.13	0.06																	
17	0.06																		
<b>TOTAL</b>	<b>4.09</b>	<b>3.64</b>	<b>3.28</b>	<b>2.74</b>	<b>2.35</b>	<b>2.06</b>	<b>1.84</b>	<b>1.66</b>	<b>1.51</b>	<b>1.39</b>	<b>1.19</b>	<b>1.05</b>	<b>0.93</b>	<b>0.89</b>	<b>0.84</b>	<b>0.71</b>	<b>0.61</b>	<b>0.54</b>	<b>0.36</b>

**W ( BSP, BSPT )**  
**INTERNAL THREAD**  
**RECOMMENDED NO OF PASSES**

NO. OF PASSES	PITCH																		
	TPI																		
	4	4.5	5	6	7	8	9	10	11	12	14	16	18	19	20	24	28	32	48
1	0.45	0.44	0.43	0.38	0.34	0.30	0.28	0.27	0.26	0.26	0.24	0.22	0.24	0.22	0.21	0.20	0.18	0.19	0.16
2	0.40	0.36	0.38	0.33	0.29	0.24	0.25	0.23	0.23	0.23	0.21	0.18	0.21	0.19	0.19	0.18	0.15	0.16	0.14
3	0.35	0.31	0.33	0.28	0.24	0.21	0.22	0.21	0.20	0.21	0.17	0.15	0.16	0.17	0.15	0.16	0.12	0.13	0.06
4	0.31	0.29	0.28	0.27	0.23	0.19	0.21	0.18	0.18	0.19	0.15	0.13	0.15	0.14	0.13	0.11	0.10	0.06	
5	0.28	0.27	0.27	0.25	0.22	0.18	0.20	0.17	0.17	0.17	0.14	0.12	0.11	0.11	0.10	0.06	0.06		
6	0.27	0.24	0.25	0.19	0.20	0.17	0.17	0.16	0.16	0.15	0.12	0.10	0.06	0.06	0.06				
7	0.25	0.23	0.23	0.18	0.19	0.17	0.17	0.14	0.13	0.12	0.10	0.09							
8	0.24	0.22	0.21	0.17	0.16	0.16	0.15	0.13	0.12	0.06	0.06	0.06							
9	0.22	0.21	0.20	0.16	0.15	0.14	0.13	0.11	0.06										
10	0.21	0.20	0.19	0.14	0.15	0.13	0.06	0.06											
11	0.20	0.19	0.18	0.12	0.12	0.11													
12	0.19	0.18	0.15	0.10	0.06	0.06													
13	0.18	0.16	0.12	0.11															
14	0.18	0.15	0.06	0.06															
15	0.17	0.13																	
16	0.13	0.06																	
17	0.06																		
<b>TOTAL</b>	<b>4.09</b>	<b>3.64</b>	<b>3.28</b>	<b>2.74</b>	<b>2.35</b>	<b>2.06</b>	<b>1.84</b>	<b>1.66</b>	<b>1.51</b>	<b>1.39</b>	<b>1.19</b>	<b>1.05</b>	<b>0.93</b>	<b>0.89</b>	<b>0.84</b>	<b>0.71</b>	<b>0.61</b>	<b>0.54</b>	<b>0.36</b>



## NPT

### EXTERNAL & INTERNAL

### RECOMMENDED NO OF PASSES

NO. OF PASSES	PITCH TPI				
	8	11.5	14	18	27
1	0.32	0.23	0.22	0.18	0.14
2	0.25	0.19	0.18	0.15	0.11
3	0.21	0.17	0.15	0.13	0.11
4	0.17	0.16	0.14	0.13	0.10
5	0.16	0.15	0.13	0.12	0.09
6	0.16	0.13	0.12	0.11	0.08
7	0.15	0.12	0.10	0.09	0.06
8	0.15	0.10	0.10	0.08	
9	0.14	0.10	0.09	0.06	
10	0.13	0.10	0.08		
11	0.13	0.09	0.06		
12	0.12	0.08			
13	0.12	0.06			
14	0.10				
15	0.08				
16	0.06				
<b>TOTAL</b>	<b>2.45</b>	<b>1.68</b>	<b>1.37</b>	<b>1.05</b>	<b>0.69</b>

## NPTF

### EXTERNAL & INTERNAL

### RECOMMENDED NO OF PASSES

NO. OF PASSES	PITCH TPI				
	8	11.5	14	18	27
1	0.31	0.22	0.21	0.17	0.14
2	0.24	0.17	0.17	0.14	0.10
3	0.20	0.16	0.14	0.13	0.09
4	0.16	0.16	0.14	0.12	0.09
5	0.16	0.14	0.14	0.11	0.08
6	0.15	0.13	0.12	0.10	0.08
7	0.15	0.12	0.10	0.09	0.06
8	0.14	0.11	0.10	0.08	
9	0.14	0.10	0.09	0.06	
10	0.13	0.10	0.08		
11	0.13	0.09	0.06		
12	0.12	0.08			
13	0.12	0.06			
14	0.10				
15	0.08				
16	0.06				
<b>TOTAL</b>	<b>2.39</b>	<b>1.64</b>	<b>1.35</b>	<b>1.00</b>	<b>0.64</b>

## TR EXTERNAL & INTERNAL RECOMMENDED NO OF PASSES

NO. OF PASSES	PITCH MM						
	7.0	6.0	5.0	4.0	3.0	2.0	1.5
1	0.38	0.36	0.34	0.32	0.31	0.30	0.24
2	0.34	0.32	0.30	0.28	0.26	0.26	0.22
3	0.28	0.28	0.25	0.23	0.23	0.22	0.17
4	0.26	0.25	0.23	0.20	0.19	0.18	0.14
5	0.25	0.24	0.22	0.19	0.19	0.16	0.12
6	0.23	0.23	0.21	0.18	0.18	0.12	0.06
7	0.22	0.22	0.19	0.17	0.15	0.06	
8	0.21	0.20	0.18	0.16	0.12		
9	0.20	0.19	0.17	0.15	0.11		
10	0.19	0.17	0.16	0.14	0.06		
11	0.19	0.16	0.14	0.12			
12	0.18	0.15	0.13	0.10			
13	0.18	0.13	0.12	0.06			
14	0.16	0.13	0.10				
15	0.16	0.12	0.06				
16	0.15	0.12					
17	0.15	0.11					
18	0.14	0.11					
19	0.12	0.06					
20	0.06						
TOTAL	4.05	3.55	2.80	2.30	1.80	1.30	0.95

## ACME EXTERNAL & INTERNAL RECOMMENDED NO OF PASSES

NO. OF PASSES	PITCH TPI							
	4	5	6	8	10	12	14	16
1	0.36	0.34	0.31	0.27	0.26	0.26	0.25	0.24
2	0.32	0.30	0.29	0.23	0.23	0.22	0.21	0.22
3	0.28	0.25	0.25	0.19	0.20	0.18	0.18	0.18
4	0.25	0.23	0.21	0.18	0.19	0.16	0.15	0.15
5	0.24	0.22	0.18	0.17	0.16	0.14	0.13	0.12
6	0.23	0.21	0.17	0.16	0.14	0.12	0.10	0.06
7	0.22	0.19	0.16	0.15	0.12	0.10	0.06	
8	0.20	0.19	0.15	0.14	0.11	0.06		
9	0.19	0.18	0.15	0.12	0.10			
10	0.17	0.17	0.14	0.12	0.06			
11	0.15	0.15	0.13	0.10				
12	0.14	0.13	0.12	0.06				
13	0.13	0.12	0.10					
14	0.12	0.10	0.06					
15	0.11	0.06						
16	0.11							
17	0.10							
18	0.10							
19	0.06							
TOTAL	3.48	2.84	2.42	1.89	1.57	1.24	1.08	0.97

## STUB ACME EXTERNAL & INTERNAL RECOMMENDED NO OF PASSES

NO OF PASSES	PITCH TPI							
	4	5	6	8	10	12	14	16
1	0.31	0.30	0.27	0.23	0.23	0.22	0.21	0.18
2	0.26	0.26	0.23	0.19	0.17	0.17	0.18	0.16
3	0.21	0.21	0.20	0.16	0.14	0.14	0.15	0.13
4	0.19	0.18	0.16	0.15	0.13	0.12	0.12	0.12
5	0.17	0.16	0.15	0.13	0.12	0.10	0.06	0.06
6	0.17	0.15	0.14	0.12	0.11	0.06		
7	0.16	0.15	0.13	0.11	0.10			
8	0.15	0.13	0.12	0.10	0.06			
9	0.15	0.12	0.10	0.06				
10	0.14	0.10	0.06					
11	0.13	0.06						
12	0.11							
13	0.06							
TOTAL	2.21	1.82	1.56	1.25	1.06	0.81	0.72	0.65

## UNJ EXTERNAL THREAD RECOMMENDED NO OF PASSES

NO. OF PASSES	PITCH TPI												
	8	9	10	11	12	13	14	16	18	20	24	28	32
1	0.29	0.29	0.26	0.25	0.25	0.24	0.23	0.22	0.21	0.20	0.20	0.18	0.18
2	0.22	0.24	0.22	0.22	0.23	0.22	0.20	0.20	0.19	0.16	0.17	0.14	0.15
3	0.20	0.22	0.19	0.19	0.19	0.18	0.17	0.17	0.16	0.14	0.13	0.10	0.11
4	0.18	0.20	0.17	0.16	0.17	0.15	0.14	0.13	0.15	0.12	0.10	0.09	0.06
5	0.16	0.17	0.15	0.15	0.15	0.13	0.11	0.10	0.10	0.10	0.06	0.06	
6	0.16	0.16	0.14	0.14	0.13	0.12	0.10	0.09	0.06	0.06			
7	0.15	0.14	0.13	0.12	0.10	0.09	0.09	0.06					
8	0.14	0.12	0.11	0.11	0.06	0.06	0.06						
9	0.13	0.10	0.10	0.06									
10	0.12	0.06	0.06										
11	0.10												
12	0.06												
TOTAL	1.91	1.70	1.53	1.40	1.28	1.19	1.10	0.97	0.87	0.78	0.66	0.57	0.50

## UNJ INTERNAL THREAD RECOMMENDED NO OF PASSES

NO. OF PASSES	PITCH TPI												
	8	9	10	11	12	13	14	16	18	20	24	28	32
1	0.29	0.29	0.26	0.25	0.25	0.24	0.23	0.22	0.20	0.20	0.17	0.14	0.14
2	0.22	0.24	0.22	0.22	0.23	0.21	0.20	0.20	0.15	0.17	0.14	0.11	0.13
3	0.20	0.21	0.18	0.18	0.19	0.18	0.17	0.17	0.13	0.15	0.12	0.10	0.11
4	0.19	0.18	0.15	0.15	0.17	0.14	0.13	0.12	0.12	0.11	0.09	0.09	0.06
5	0.18	0.16	0.14	0.14	0.13	0.12	0.10	0.09	0.10	0.06	0.06	0.06	
6	0.16	0.14	0.13	0.12	0.10	0.10	0.09	0.06	0.06				
7	0.15	0.12	0.11	0.11	0.06	0.06	0.06						
8	0.14	0.10	0.10	0.06									
9	0.10	0.06	0.06										
10	0.06												
TOTAL	1.69	1.50	1.35	1.23	1.13	1.05	0.98	0.86	0.76	0.69	0.58	0.50	0.44

## MJ INTERNAL THREAD RECOMMENDED NO OF PASSES

NO. OF PASSES	PITCH MM					
	1.0	1.25	1.5	2.0	2.5	3.0
1	0.16	0.17	0.22	0.23	0.24	0.24
2	0.13	0.14	0.19	0.21	0.21	0.20
3	0.11	0.12	0.14	0.18	0.18	0.18
4	0.09	0.10	0.11	0.16	0.16	0.17
5	0.06	0.09	0.09	0.14	0.14	0.16
6		0.06	0.06	0.10	0.13	0.15
7				0.06	0.12	0.13
8					0.10	0.12
9					0.06	0.10
10						0.09
11						0.06
12						
TOTAL	0.55	0.68	0.81	1.08	1.34	1.60

## MJ EXTERNAL THREAD RECOMMENDED NO OF PASSES

NO OF PASSES	PITCH MM					
	1.0	1.25	1.5	2.0	2.5	3.0
1	0.18	0.18	0.22	0.23	0.25	0.26
2	0.15	0.16	0.20	0.22	0.21	0.22
3	0.13	0.14	0.18	0.18	0.19	0.19
4	0.10	0.12	0.15	0.16	0.16	0.17
5	0.06	0.10	0.11	0.14	0.15	0.16
6		0.06	0.06	0.12	0.14	0.15
7				0.10	0.13	0.14
8				0.06	0.12	0.13
9					0.10	0.12
10					0.06	0.11
11						0.09
12						0.06
TOTAL	0.62	0.76	0.92	1.21	1.51	1.80

## RD (DIN 20400)

EXTERNAL & INTERNAL  
RECOMMENDED NO OF PASSES

NO. OF PASSES	PITCH MM			
	6.0	5.0	4.0	3.0
1	0.35	0.32	0.25	0.24
2	0.33	0.28	0.24	0.23
3	0.32	0.27	0.23	0.21
4	0.31	0.26	0.22	0.20
5	0.30	0.25	0.21	0.19
6	0.29	0.24	0.20	0.18
7	0.26	0.22	0.19	0.14
8	0.23	0.20	0.18	0.11
9	0.22	0.19	0.16	0.10
10	0.19	0.16	0.14	0.09
11	0.17	0.15	0.12	0.06
12	0.15	0.13	0.10	
13	0.12	0.12	0.06	
14	0.10	0.06		
15	0.06			
TOTAL	3.40	2.85	2.30	1.75

## RD (DIN 405)

EXTERNAL & INTERNAL  
RECOMMENDED NO OF PASSES

NO. OF PASSES	PITCH TPI			
	4	6	8	10
1	0.35	0.25	0.24	0.23
2	0.32	0.24	0.22	0.21
3	0.31	0.22	0.20	0.19
4	0.30	0.21	0.19	0.18
5	0.29	0.20	0.18	0.16
6	0.28	0.19	0.16	0.14
7	0.25	0.18	0.14	0.11
8	0.22	0.16	0.11	0.09
9	0.21	0.15	0.10	0.06
10	0.18	0.13	0.09	
11	0.16	0.12	0.06	
12	0.13	0.11		
13	0.12	0.06		
14	0.10			
15	0.06			
TOTAL	3.28	2.22	1.69	1.37

## PG

EXTERNAL & INTERNAL  
RECOMMENDED NO OF PASSES

NO. OF PASSES	PITCH TPI		
	20	18	16
1	0.17	0.18	0.19
2	0.15	0.14	0.16
3	0.14	0.12	0.13
4	0.10	0.10	0.11
5	0.06	0.09	0.10
6		0.06	0.09
7			0.06
TOTAL	0.62	0.69	0.78

## AMERICAN BUTTRESS

### EXTERNAL & INTERNAL

#### RECOMMENDED NO OF PASSES

NO. OF PASSES	PITCH TPI					
	6	8	10	12	16	20
1	0.28	0.25	0.22	0.21	0.20	0.18
2	0.24	0.22	0.20	0.19	0.18	0.16
3	0.21	0.19	0.19	0.18	0.17	0.14
4	0.20	0.19	0.17	0.16	0.14	0.13
5	0.20	0.17	0.16	0.15	0.13	0.12
6	0.19	0.16	0.15	0.14	0.12	0.10
7	0.19	0.16	0.13	0.13	0.10	0.06
8	0.18	0.15	0.12	0.12	0.06	
9	0.17	0.14	0.12	0.11		
10	0.16	0.13	0.11	0.06		
11	0.15	0.12	0.10			
12	0.14	0.11	0.06			
13	0.14	0.10				
14	0.13	0.06				
15	0.12					
16	0.10					
17	0.06					
<b>TOTAL</b>	<b>2.86</b>	<b>2.15</b>	<b>1.73</b>	<b>1.45</b>	<b>1.10</b>	<b>0.89</b>

## SAGENGWINDE ( DIN 513 )

### EXTERNAL

#### RECOMMENDED NO OF PASSES

NO. OF PASSES	PITCH MM		
	4.0	3.0	2.0
1	0.32	0.30	0.29
2	0.30	0.28	0.26
3	0.27	0.26	0.24
4	0.25	0.24	0.19
5	0.23	0.22	0.18
6	0.21	0.21	0.17
7	0.20	0.20	0.15
8	0.19	0.18	0.14
9	0.18	0.17	0.11
10	0.17	0.15	0.06
11	0.16	0.14	
12	0.15	0.13	
13	0.15	0.11	
14	0.15	0.06	
15	0.14		
16	0.14		
17	0.13		
18	0.12		
19	0.06		
<b>TOTAL</b>	<b>3.52</b>	<b>2.65</b>	<b>1.79</b>

## SAGENGWINDE ( DIN 513 )

### INTERNAL

#### RECOMMENDED NO OF PASSES

NO. OF PASSES	PITCH MM		
	4.0	3.0	2.0
1	0.32	0.31	0.29
2	0.30	0.29	0.27
3	0.27	0.27	0.25
4	0.24	0.24	0.21
5	0.23	0.23	0.18
6	0.21	0.22	0.16
7	0.20	0.20	0.12
8	0.19	0.19	0.06
9	0.18	0.16	
10	0.17	0.13	
11	0.16	0.06	
12	0.15		
13	0.14		
14	0.13		
15	0.10		
16	0.06		
<b>TOTAL</b>	<b>3.05</b>	<b>2.30</b>	<b>1.54</b>

## API EXTERNAL & INTERNAL RECOMMENDED NO OF PASSES

NO. OF PASSES	V0.038R 4 TPI		V0.050 4 TPI		V0.040 5 TPI	BUTTRESS CASING 5 TPI	
	2 IPF	3 IPF	2 IPF	3 IPF	3 IPF	0.75 IPF	1.0 IPF
1	0.45	0.45	0.44	0.44	0.41	0.24	0.24
2	0.38	0.38	0.39	0.39	0.36	0.22	0.22
3	0.33	0.33	0.34	0.34	0.32	0.18	0.18
4	0.30	0.30	0.31	0.31	0.28	0.14	0.14
5	0.28	0.28	0.28	0.28	0.26	0.12	0.12
6	0.24	0.24	0.26	0.26	0.24	0.12	0.12
7	0.22	0.22	0.24	0.24	0.22	0.12	0.12
8	0.20	0.20	0.23	0.23	0.20	0.10	0.10
9	0.18	0.18	0.21	0.21	0.18	0.10	0.10
10	0.14	0.14	0.19	0.19	0.14	0.10	0.10
11	0.13	0.13	0.18	0.18	0.13	0.10	0.10
12	0.12	0.12	0.16	0.16	0.12	0.06	0.06
13	0.11	0.10	0.14	0.14	0.11		
14	0.06	0.06	0.13	0.13	0.06		
15			0.12	0.12			
16			0.10	0.11			
17			0.06	0.06			
<b>TOTAL</b>	3.14	3.13	3.79	3.78	3.03	1.60	1.60

## API EXTERNAL & INTERNAL RECOMMENDED NO OF PASSES

NO. OF PASSES	EXTREME LINE CASING 6 TPI 1.5 IPF		EXTREME LINE CASING 5 TPI 1.25 IPF		API ROUND 0.75 IPF 8 TPI		API ROUND 0.75 IPF 10 TPI	
	EXTERNAL	INTERNAL	EXTERNAL	INTERNAL	EXTERNAL	INTERNAL	EXTERNAL	INTERNAL
1	0.23	0.25	0.25	0.25	0.25	0.25	0.25	0.25
2	0.20	0.20	0.22	0.23	0.22	0.22	0.20	0.20
3	0.16	0.17	0.20	0.21	0.20	0.20	0.17	0.17
4	0.15	0.15	0.18	0.19	0.18	0.18	0.15	0.15
5	0.13	0.14	0.15	0.16	0.16	0.16	0.14	0.14
6	0.12	0.13	0.14	0.15	0.15	0.15	0.13	0.13
7	0.11	0.12	0.13	0.14	0.14	0.14	0.12	0.12
8	0.10	0.12	0.12	0.13	0.13	0.13	0.12	0.12
9	0.06	0.10	0.11	0.12	0.12	0.12	0.10	0.10
10		0.06	0.10	0.11	0.11	0.11	0.06	0.06
11			0.10	0.11	0.11	0.11		
12			0.06	0.10	0.06	0.06		
13				0.06				
<b>TOTAL</b>	1.26	1.44	1.76	1.96	1.83	1.83	1.44	1.44

## MULTITOOTH INSERTS RECOMMENDED NO OF PASSES

STANDARD	PITCH	TEETH	CATALOG NUMBER	NO OF PASSES	DEPTH OF CUT PER PASS			
					1	2	3	4
ISO EXTERNAL	1.0	3	ISO1.0 3M ER16	2	0.37	0.26		
	1.5	2	ISO1.5 2M ER16	3	0.44	0.29	0.21	
	1.5	3	ISO1.5 3M ER22	2	0.56	0.37		
	2.0	2	ISO2.0 2M ER22	3	0.56	0.41	0.28	
	2.0	3	ISO2.0 3M ER22	2	0.77	0.48		
	2.5	2	ISO2.5 2M ER22	4	0.55	0.40	0.34	0.26
	3.0	2	ISO3.0 2M ER27	4	0.60	0.52	0.40	0.32
ISO INTERNAL	1.0	3	ISO1.0 3M IR16	2	0.34	0.24		
	1.5	2	ISO1.5 2M IR16	3	0.39	0.28	0.20	
	1.5	3	ISO1.5 3M IR22	2	0.52	0.35		
	2.0	2	ISO2.0 2M IR22	3	0.53	0.37	0.25	
	2.0	3	ISO2.0 3M IR22	2	0.72	0.43		
	3.0	2	ISO3.0 2M IR27	4	0.60	0.45	0.37	0.29
UN EXTERNAL	20	2	UN20 2M ER16	3	0.38	0.24	0.18	
	16	2	UN16 2M ER16	3	0.45	0.30	0.22	
	14	2	UN14 2M ER16	3	0.52	0.38	0.24	
	16	3	UN16 3M ER22	2	0.57	0.40		
	12	2	UN12 2M ER22	3	0.58	0.41	0.31	
	12	3	UN12 3M ER22	2	0.79	0.51		
	8	2	UN8 2M ER27	4	0.64	0.53	0.44	0.35
UN INTERNAL	20	2	UN20 2M IR16	3	0.35	0.24	0.18	
	16	2	UN16 2M IR16	3	0.44	0.27	0.21	
	14	2	UN14 2M IR16	3	0.47	0.36	0.25	
	12	2	UN12 2M IR16	3	0.54	0.38	0.30	
	16	3	UN16 3M IR22	2	0.54	0.38		
	12	2	UN12 2M IR22	3	0.54	0.38	0.30	
	12	3	UN12 3M IR22	2	0.73	0.49		
	8	2	UN8 2M IR27	4	0.65	0.49	0.39	0.30
W EXTERNAL	14	2	W14 2M ER16	3	0.54	0.35	0.27	
	14	3	W14 3M ER22	2	0.69	0.47		
	11	2	W11 2M ER22	3	0.66	0.48	0.34	
W INTERNAL	14	2	W14 2M IR16	3	0.54	0.35	0.27	
	14	3	W14 3M IR22	2	0.69	0.47		
	11	2	W11 2M IR22	3	0.66	0.48	0.34	
NPT EXTERNAL	11.5	2	NPT11.5 2M ER22	4	0.53	0.47	0.38	0.30
	11.5	3	NPT11.5 3M ER27	3	0.77	0.54	0.37	
	8	2	NPT8 2M ER27	4	0.82	0.60	0.54	0.45
NPT INTERNAL	11.5	2	NPT11.5 2M IR22	4	0.53	0.47	0.38	0.30
	11.5	3	NPT11.5 3M IR27	3	0.77	0.54	0.37	
	8	2	NPT8 2M IR27	4	0.82	0.60	0.54	0.45
NPTF EXTERNAL	11.5	2	NPTF11.5 2M ER22	4	0.52	0.46	0.38	0.30
NPTF INTERNAL	11.5	2	NPTF11.5 2M IR22	4	0.52	0.46	0.38	0.30
API ROUND EXTERNAL	10	2	APIRD10 2M ER22	3	0.61	0.49	0.31	
	10	3	APIRD10 3M ER27	2	0.99	0.42		
	8	2	APIRD8 2M ER27	3	0.82	0.59	0.40	
API ROUND INTERNAL	10	2	APIRD10 2M IR22	3	0.61	0.49	0.31	
	10	3	APIRD10 3M IR27	2	0.99	0.42		
	8	2	APIRD8 2M IR27	3	0.82	0.59	0.40	

## TAPER PIPE THREAD :NPT

ANSI/ASME B 1.20.1-1983

INTERNAL THREAD

American National Standard Taper Pipe Threads

THREAD SIZE	PITCH TPI	PITCH	PROFILE DEPTH	RECOMMENDED TOOLS	
				INSERT	TOOLHOLDER
NPT 1/16	27	0.941	0.69	NPT27 IR06	HIR0012H06
NPT 1/8	27	0.941	0.69	NPT27 IR08	HIR0016K08
NPT 1/4	18	1.411	1.05	NPT18 IR08	HIR0016K08
NPT 3/8	18	1.411	1.05	NPT18 IR11	HIR0010K11
NPT 1/2	14	1.814	1.37	NPT14 IR16	HIR0013M16
NPT 3/4	14	1.814	1.37	NPT14 IR16	HIR0016P16
NPT 1	11.5	2.209	1.68	NPT11.5 IR16	HIR0020P16
NPT 1 1/4	11.5	2.209	1.68	NPT11.5 IR16	HIR0025R16
NPT 1 1/2	11.5	2.209	1.68	NPT11.5 IR16	HIR0032S16
NPT 2	11.5	2.209	1.68	NPT11.5 IR16	HIR0032S16
NPT 2 1/2	8	3.175	2.45	NPT8 IR16	HIR0040T16
NPT 3	8	3.175	2.45	NPT8 IR16	HIR0040T16
NPT 3 1/2	8	3.175	2.45	NPT8 IR16	HIR0040T16
NPT 4	8	3.175	2.45	NPT8 IR16	HIR0040T16
NPT 5	8	3.175	2.45	NPT8 IR16	HIR0040T16

## TAPER PIPE THREAD :NPTF

ANSI B 1.20.3-1976

INTERNAL THREAD

American National Standard Dryseal Pipe Threads

THREAD SIZE	PITCH TPI	PITCH	PROFILE DEPTH	RECOMMENDED TOOLS	
				INSERT	TOOLHOLDER
NPTF 1/16	27	0.941	0.64	NPTF27 IR06	HIR0012H06
NPTF 1/8	27	0.941	0.64	NPTF27 IR08	HIR0016K08
NPTF 1/4	18	1.411	1.00	NPTF18 IR08	HIR0016K08
NPTF 3/8	18	1.411	1.00	NPTF18 IR11	HIR0010K11
NPTF 1/2	14	1.814	1.35	NPTF14 IR16	HIR0013M16
NPTF 3/4	14	1.814	1.35	NPTF14 IR16	HIR0016P16
NPTF 1	11.5	2.209	1.64	NPTF11.5 IR16	HIR0020P16
NPTF 1 1/4	11.5	2.209	1.64	NPTF11.5 IR16	HIR0025R16
NPTF 1 1/2	11.5	2.209	1.64	NPTF11.5 IR16	HIR0032S16
NPTF 2	11.5	2.209	1.64	NPTF11.5 IR16	HIR0032S16
NPTF 2 1/2	8	3.175	2.39	NPTF8 IR16	HIR0040T16
NPTF 3	8	3.175	2.39	NPTF8 IR16	HIR0040T16



## PARALLEL PIPE THREADS

BSP (G)

INTERNAL THREAD

THREAD SIZE	PITCH TPI	PITCH	PROFILE DEPTH	BORE DIAMETER	RECOMMENDED TOOLS	
					INSERT	TOOLHOLDER
G1/16	28	0.907	0.581	6.561	W28 IR06	HIR0012H06
G1/8	28	0.907	0.581	8.556	W28 IR08	HIR0016K08
G1/4	19	1.337	0.856	11.445	W19 IR08	HIR0016K08
G3/8	19	1.337	0.856	14.950	W19 IR11	HIR0010K11
G1/2	14	1.814	1.162	18.631	W14 IR16	HIR0013M16
G5/8	14	1.814	1.162	20.587	W14 IR16	HIR0016P16
G3/4	14	1.814	1.162	24.117	W14 IR16	HIR0016P16
G7/8	14	1.814	1.162	27.877	W14 IR16	HIR0020P16
G1	11	2.309	1.479	30.291	W11 IR16	HIR0020P16
G1 1/8	11	2.309	1.479	34.939	W11 IR16	HIR0025R16
G1 1/4	11	2.309	1.479	38.952	W11 IR16	HIR0025R16
G1 1/2	11	2.309	1.479	44.845	W11 IR16	HIR0032S16
G1 3/4	11	2.309	1.479	50.788	W11 IR16	HIR0032S16
G2	11	2.309	1.479	56.656	W11 IR16	HIR0032S16

## TAPER PIPE THREADS

BSPT (Rc)

INTERNAL THREAD

THREAD SIZE	PITCH TPI	PITCH	PROFILE DEPTH	BORE DIAMETER	RECOMMENDED TOOLS	
					INSERT	TOOLHOLDER
Rc 1/16	28	0.907	0.581	6.561	BSPT28 IR06	HIR0012H06
Rc 1/8	28	0.907	0.581	8.556	BSPT28 IR08	HIR0016K08
Rc 1/4	19	1.337	0.856	11.445	BSPT19 IR08	HIR0016K08
Rc 3/8	19	1.337	0.856	14.950	BSPT19 IR11	HIR0010K11
Rc 1/2	14	1.814	1.162	18.631	BSPT14 IR16	HIR0013M16
Rc 5/8	14	1.814	1.162	20.587	BSPT14 IR16	HIR0016P16
Rc 3/4	14	1.814	1.162	24.117	BSPT14 IR16	HIR0016P16
Rc 7/8	14	1.814	1.162	27.877	BSPT14 IR16	HIR0020P16
Rc 1	11	2.309	1.479	30.291	BSPT11 IR16	HIR0020P16
Rc 1 1/8	11	2.309	1.479	34.939	BSPT11 IR16	HIR0025R16
Rc 1 1/4	11	2.309	1.479	38.952	BSPT11 IR16	HIR0025R16
Rc 1 1/2	11	2.309	1.479	44.845	BSPT11 IR16	HIR0032S16
Rc 1 3/4	11	2.309	1.479	50.788	BSPT11 IR16	HIR0032S16
Rc 2	11	2.309	1.479	56.656	BSPT11 IR16	HIR0032S16



## EROJET LTD.

📍 Adom st. 1, Industrial Park Misgav 2017900, P.O. Box 17, Israel

☎ Tel: +972-49990026

✉ sales@erojet-tools.com

☎ Fax: +972-49990027

🌐 www.erojet-tools.com